

SBM

Single Water Coil Connection Locations

☐ SCM/ MCM/ FCM/ VCM/ STM/ MTM Segments

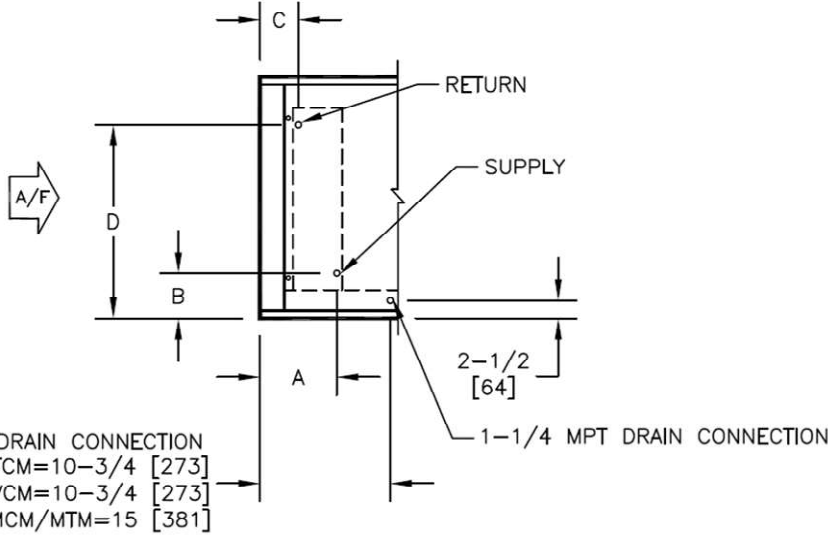

Notes:

1. All Dimensions are inches.
2. All drawings subject to change without prior notice.
3. See selection program for connection sizes.
4. Chilled water coils are only available in 4, 6, or 8 rows.
5. Hot water coils are only available in 1, 2, 3, or 4 rows.
6. SCM and STM can have up to 4 rows of a single heating coil and no drain connection.
7. FCM and VCM can have up to a total of 8 rows of coil.
8. MCM and MTM can have up to a total of 10 rows of coil.

Unit Size	1 Row								2 Row							
	A		B		C		D		A		B		C		D	
	Inches	mm	Inches	mm	Inches	mm	Inches	mm	Inches	mm	Inches	mm	Inches	mm	Inches	mm
02	7 1/4	185	6 1/4	159	5	127	16 3/4	425	7	178	6 1/4	159	5	127	16 3/4	425
03	7 1/4	185	6 1/4	159	5	127	16 3/4	425	7	178	6 1/4	159	5	127	16 3/4	425
04	7 1/4	185	6 1/2	165	5	127	17	432	7	178	6 1/2	165	5	127	17	432
06	7 1/4	185	6 1/2	165	5	127	24 1/2	622	7	178	6 1/2	165	5	127	24 1/2	622
08	7 1/4	185	6 3/4	171	5	127	29 3/4	756	7	178	6 3/4	171	5	127	29 3/4	756
10	7 1/4	185	6 1/2	165	5	127	29 1/2	749	7	178	6 1/2	165	5	127	29 1/2	749
12	7 1/4	185	7 1/4	184	5	127	35 1/4	895	7	178	7 1/4	184	5	127	35 1/4	895
14	7 1/4	185	7 1/4	184	5	127	37 3/4	959	7	178	7 1/4	184	5	127	37 3/4	959
17	7 1/4	185	7 1/2	191	5	127	38	965	7	178	7 1/2	191	5	127	38	965

Unit Size	3 Row								4 Row							
	A		B		C		D		A		B		C		D	
	Inches	mm	Inches	mm	Inches	mm	Inches	mm	Inches	mm	Inches	mm	Inches	mm	Inches	mm
02	8	204	6 1/4	159	5 3/4	146	16 3/4	425	9	229	6 1/4	159	6	152	16 3/4	425
03	8	204	6 1/4	159	5 3/4	146	16 3/4	425	9	229	6 1/4	159	6	152	16 3/4	425
04	8	204	6 1/2	165	5 3/4	146	17	432	9	229	6 1/2	165	6	152	17	432
06	8	204	6 1/2	165	5 3/4	146	24 1/2	622	9	229	6 1/2	165	6	152	24 1/2	622
08	8	204	6 3/4	171	5 3/4	146	29 3/4	756	9	229	6 3/4	171	6	152	29 3/4	756
10	8	204	6 1/2	165	5 3/4	146	29 1/2	749	9	229	6 1/2	165	6	152	29 1/2	749
12	8	204	7 1/4	184	5 3/4	146	35 1/4	895	9	229	7 1/4	184	6	152	35 1/4	895
14	8	204	7 1/4	184	5 3/4	146	37 3/4	959	9	229	7 1/4	184	6	152	37 3/4	959
17	8	204	7 1/2	191	5 3/4	146	38	965	9	229	7 1/2	191	6	152	38	965

Unit Size	6 Row								8 Row							
	A		B		C		D		A		B		C		D	
	Inches	mm	Inches	mm	Inches	mm	Inches	mm	Inches	mm	Inches	mm	Inches	mm	Inches	mm
02	9 3/4	248	6 1/4	159	6 1/4	159	16 3/4	425	11 3/4	299	6 1/4	159	6 1/4	159	16 3/4	425
03	9 3/4	248	6 1/4	159	6 1/4	159	16 3/4	425	11 3/4	299	6 1/4	159	6 1/4	159	16 3/4	425
04	9 3/4	248	6 1/2	165	6 1/4	159	17	432	11 3/4	299	6 1/2	165	6 1/4	159	17	432
06	9 3/4	248	6 1/2	165	6 1/4	159	24 1/2	622	11 3/4	299	6 1/2	165	6 1/4	159	24 1/2	622
08	9 3/4	248	6 3/4	171	6 1/4	159	29 3/4	756	11 3/4	299	6 3/4	171	6 1/4	159	29 3/4	756
10	9 3/4	248	6 1/2	165	6 1/4	159	29 1/2	749	11 3/4	299	6 1/2	165	6 1/4	159	29 1/2	749
12	9 3/4	248	7 1/4	184	6 1/4	159	35 1/4	895	11 3/4	299	7 1/4	184	6 1/4	159	35 1/4	895
14	9 3/4	248	7 1/4	184	6 1/4	159	37 3/4	959	11 3/4	299	7 1/4	184	6 1/4	159	37 3/4	959
17	9 3/4	248	7 1/2	191	6 1/4	159	38	965	11 3/4	299	7 1/2	191	6 1/4	159	38	965

SBM

1 Row HW Preheat w/ Coil 2 Chilled Water Connection Locations

MCM/ FCM/ VCM/ MTM Segments

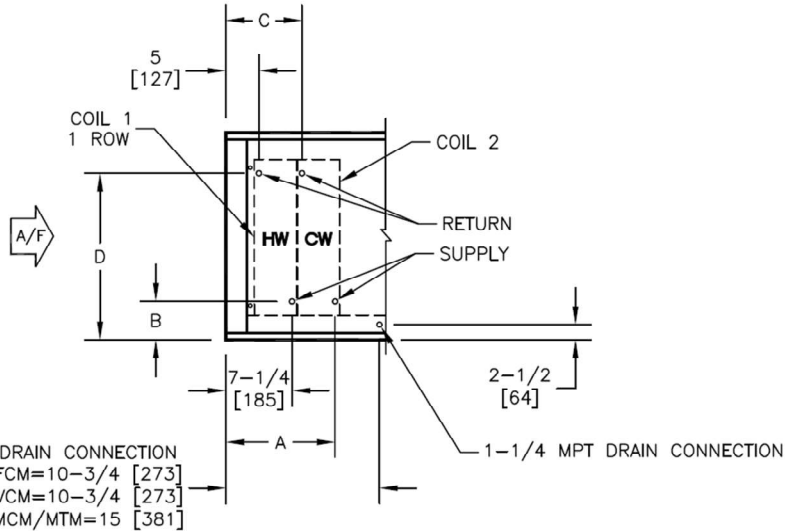

Notes:

1. All Dimensions are inches. All dimensions are +/-1/8" [3mm]. All metric values are rounded to the nearest millimeter.
2. All drawings subject to change without prior notice.
3. See selection program for connection sizes.
4. Chilled water coils are only available in 4, 6, or 8 rows.
5. Hot water coils are only available in 1, 2, 3, or 4 rows.
6. FCM and VCM can have up to a total of 8 rows of coil.
7. MCM and MTM can have up to a total of 10 rows of coil.

Coil 2 Chilled Water																								
Unit Size	4 Row								6 Row								8 Row							
	A		B		C		D		A		B		C		D		A		B		C		D	
	Inches	mm	Inches	mm	Inches	mm	Inches	mm	Inches	mm	Inches	mm	Inches	mm	Inches	mm	Inches	mm	Inches	mm	Inches	mm	Inches	mm
02	12 1/2	318	6 1/4	159	9 1/2	241	16 3/4	425	13 1/4	337	6 1/4	159	9 3/4	248	16 3/4	425	15 1/4	388	6 1/4	159	9 3/4	127	16 3/4	425
03	12 1/2	318	6 1/4	159	9 1/2	241	16 3/4	425	13 1/4	337	6 1/4	159	9 3/4	248	16 3/4	425	15 1/4	388	6 1/4	159	9 3/4	127	16 3/4	425
04	12 1/2	318	6 1/2	165	9 1/2	241	17	432	13 1/4	337	6 1/2	165	9 3/4	248	17	432	15 1/4	388	6 1/2	165	9 3/4	127	17	432
06	12 1/2	318	6 1/2	165	9 1/2	241	24 1/2	622	13 1/4	337	6 1/2	165	9 3/4	248	24 1/2	622	15 1/4	388	6 1/2	165	9 3/4	127	24 1/2	622
08	12 1/2	318	6 3/4	171	9 1/2	241	29 3/4	756	13 1/4	337	6 3/4	171	9 3/4	248	29 3/4	756	15 1/4	388	6 3/4	171	9 3/4	127	29 3/4	756
10	12 1/2	318	6 1/2	165	9 1/2	241	29 1/2	749	13 1/4	337	6 1/2	165	9 3/4	248	29 1/2	749	15 1/4	388	6 1/2	165	9 3/4	127	29 1/2	749
12	12 1/2	318	7 1/4	184	9 1/2	241	35 1/4	895	13 1/4	337	7 1/4	184	9 3/4	248	35 1/4	895	15 1/4	388	7 1/4	184	9 3/4	127	35 1/4	895
14	12 1/2	318	7 1/4	184	9 1/2	241	37 3/4	959	13 1/4	337	7 1/4	184	9 3/4	248	37 3/4	959	15 1/4	388	7 1/4	184	9 3/4	127	37 3/4	959
17	12 1/2	318	7 1/2	191	9 1/2	241	38	965	13 1/4	337	7 1/2	191	9 3/4	248	38	965	15 1/4	388	7 1/2	191	9 3/4	127	38	965

SBM

2 Row HW Preheat w/ Coil 2 Chilled Water Connection Locations

MCM/ FCM/ VCM/ MTM Segments

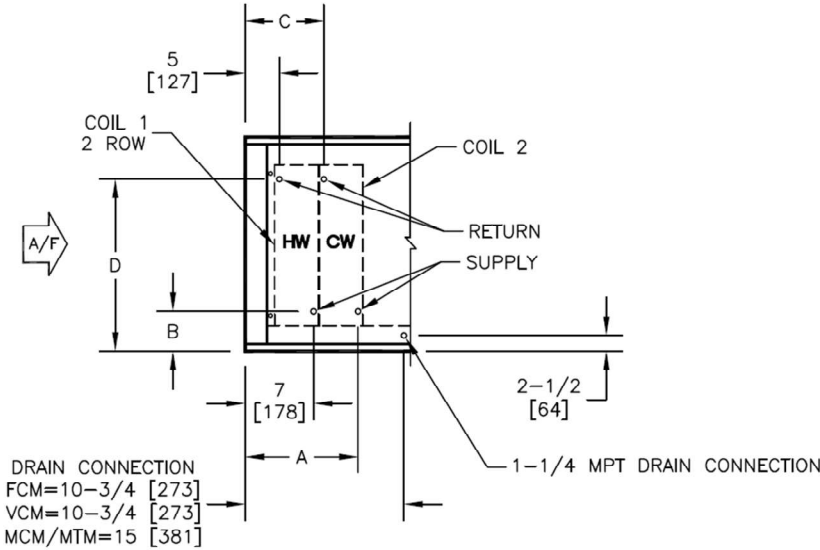

Notes:

1. All Dimensions are inches. All dimensions are +/-1/8" [3mm]. All metric values are rounded to the nearest millimeter.
2. All drawings subject to change without prior notice.
3. See selection program for connection sizes.
4. Chilled water coils are only available in 4, 6, or 8 rows.
5. Hot water coils are only available in 1, 2, 3, or 4 rows.
6. FCM and VCM can have up to a total of 8 rows of coil.
7. MCM and MTM can have up to a total of 10 rows of coil.

Coil 2 Chilled Water																								
Unit Size	4 Row								6 Row								8 Row							
	A		B		C		D		A		B		C		D		A		B		C		D	
	Inches	mm	Inches	mm	Inches	mm	Inches	mm	Inches	mm	Inches	mm	Inches	mm	Inches	mm	Inches	mm	Inches	mm	Inches	mm	Inches	mm
02	12 1/4	312	6 1/4	159	9 1/4	235	16 3/4	425	13	331	6 1/4	159	9 1/2	241	16 3/4	425	15	381	6 1/4	159	9 1/2	241	16 3/4	425
03	12 1/4	312	6 1/4	159	9 1/4	235	16 3/4	425	13	331	6 1/4	159	9 1/2	241	16 3/4	425	15	381	6 1/4	159	9 1/2	241	16 3/4	425
04	12 1/4	312	6 1/2	165	9 1/4	235	17	432	13	331	6 1/2	165	9 1/2	241	17	432	15	381	6 1/2	165	9 1/2	241	17	432
06	12 1/4	312	6 1/2	165	9 1/4	235	24 1/2	622	13	331	6 1/2	165	9 1/2	241	24 1/2	622	15	381	6 1/2	165	9 1/2	241	24 1/2	622
08	12 1/4	312	6 3/4	171	9 1/4	235	29 3/4	756	13	331	6 3/4	171	9 1/2	241	29 3/4	756	15	381	6 3/4	171	9 1/2	241	29 3/4	756
10	12 1/4	312	6 1/2	165	9 1/4	235	29 1/2	749	13	331	6 1/2	165	9 1/2	241	29 1/2	749	15	381	6 1/2	165	9 1/2	241	29 1/2	749
12	12 1/4	312	7 1/4	184	9 1/4	235	35 1/4	895	13	331	7 1/4	184	9 1/2	241	35 1/4	895	15	381	7 1/4	184	9 1/2	241	35 1/4	895
14	12 1/4	312	7 1/4	184	9 1/4	235	37 3/4	959	13	331	7 1/4	184	9 1/2	241	37 3/4	959	15	381	7 1/4	184	9 1/2	241	37 3/4	959
17	12 1/4	312	7 1/2	191	9 1/4	235	38	965	13	331	7 1/2	191	9 1/2	241	38	965	15	381	7 1/2	191	9 1/2	241	38	965

SBM

3 Row HW Preheat w/ Coil 2 Chilled Water Connection Locations

MCM/ FCM/ VCM/ MTM Segments

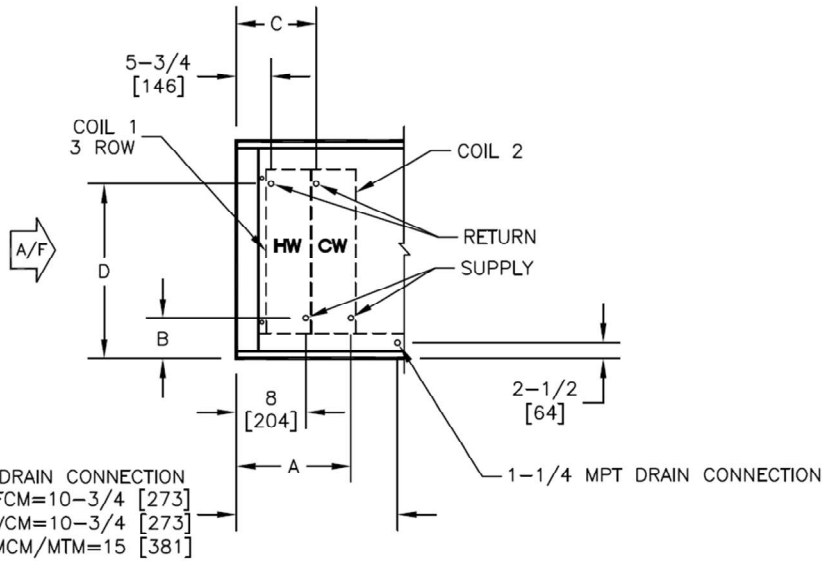

Notes:

1. All Dimensions are inches. All dimensions are +/-1/8" [3mm]. All metric values are rounded to the nearest millimeter.
2. All drawings subject to change without prior notice.
3. See selection program for connection sizes.
4. Chilled water coils are only available in 4 or 6 rows.
5. Hot water coils are only available in 1, 2, 3, or 4 rows.
6. FCM and VCM can have up to a total of 8 rows of coil.
7. MCM and MTM can have up to a total of 10 rows of coil.

Coil 2 Chilled Water

Unit Size	Coil 2 Chilled Water															
	4 Row								6 Row							
	A		B		C		D		A		B		C		D	
	Inches	mm	Inches	mm	Inches	mm	Inches	mm	Inches	mm	Inches	mm	Inches	mm	Inches	mm
02	14	356	6 1/4	159	11	279	16 3/4	425	14 3/4	375	16 3/4	425	11 1/4	286	16 3/4	425
03	14	356	6 1/4	159	11	279	16 3/4	425	14 3/4	375	16 3/4	425	11 1/4	286	16 3/4	425
04	14	356	6 1/2	165	11	279	17	432	14 3/4	375	17	432	11 1/4	286	17	432
06	14	356	6 1/2	165	11	279	24 1/2	622	14 3/4	375	24 1/2	622	11 1/4	286	24 1/2	622
08	14	356	6 3/4	171	11	279	29 3/4	756	14 3/4	375	29 3/4	756	11 1/4	286	29 3/4	756
10	14	356	6 1/2	165	11	279	29 1/2	749	14 3/4	375	29 1/2	749	11 1/4	286	29 1/2	749
12	14	356	7 1/4	184	11	279	35 1/4	895	14 3/4	375	35 6/25	895	11 1/4	286	35 6/25	895
14	14	356	7 1/4	184	11	279	37 3/4	959	14 3/4	375	37 3/4	959	11 1/4	286	37 3/4	959
17	14	356	7 1/2	191	11	279	38	965	14 3/4	375	38	965	11 1/4	286	38	965

SBM

4 Row HW Preheat w/ Coil 2 Chilled Water Connection Locations

☐ MCM/ FCM/ VCM/ MTM Segments

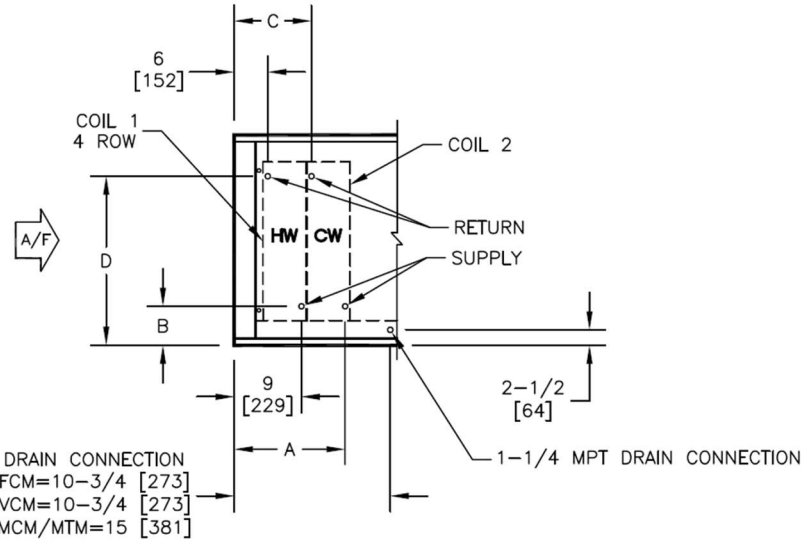

Notes:

1. All Dimensions are inches. All dimensions are +/-1/8" [3mm]. All metric values are rounded to the nearest millimeter.
2. All drawings subject to change without prior notice.
3. See selection program for connection sizes.
4. Chilled water coils are only available in 4 or 6 rows.
5. Hot water coils are only available in 1, 2, 3, or 4 rows.
6. FCM and VCM can have up to a total of 8 rows of coil.
7. MCM and MTM can have up to a total of 10 rows of coil.

Coil 2 Chilled Water

Unit Size	4 Row								6 Row							
	A		B		C		D		A		B		C		D	
	Inches	mm	Inches	mm	Inches	mm	Inches	mm	Inches	mm	Inches	mm	Inches	mm	Inches	mm
02	15 1/4	388	6 1/4	159	12 1/4	311	16 3/4	425	16	407	6 1/4	159	12 1/2	318	16 3/4	425
03	15 1/4	388	6 1/4	159	12 1/4	311	16 3/4	425	16	407	6 1/4	159	12 1/2	318	16 3/4	425
04	15 1/4	388	6 1/2	165	12 1/4	311	17	432	16	407	6 1/2	165	12 1/2	318	17	432
06	15 1/4	388	6 1/2	165	12 1/4	311	24 1/2	622	16	407	6 1/2	165	12 1/2	318	24 1/2	622
08	15 1/4	388	6 3/4	171	12 1/4	311	29 3/4	756	16	407	6 3/4	171	12 1/2	318	29 3/4	756
10	15 1/4	388	6 1/2	165	12 1/4	311	29 1/2	749	16	407	6 1/2	165	12 1/2	318	29 1/2	749
12	15 1/4	388	7 1/4	184	12 1/4	311	35 6/25	895	16	407	7 1/4	184	12 1/2	318	35 6/25	895
14	15 1/4	388	7 1/4	184	12 1/4	311	37 3/4	959	16	407	7 1/4	184	12 1/2	318	37 3/4	959
17	15 1/4	388	7 1/2	191	12 1/4	311	38	965	16	407	7 1/2	191	12 1/2	318	38	965

SBM

4 Row CW Coil w/ HW Reheat Coil Connection Locations

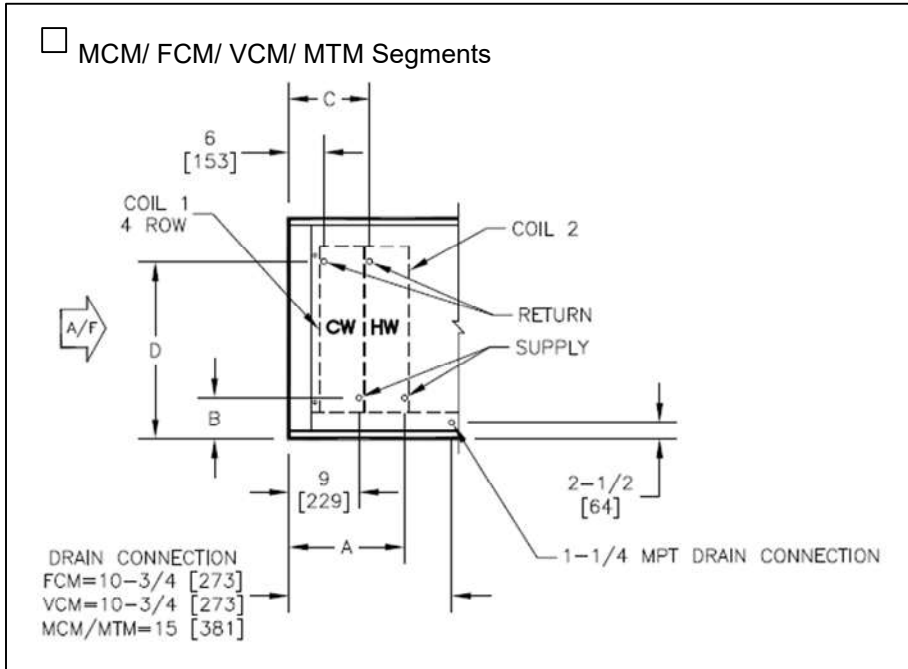

Notes:

1. All Dimensions are inches. All dimensions are +/-1/8" [3mm]. All metric values are rounded to the nearest millimeter.
2. All drawings subject to change without prior notice.
3. See selection program for connection sizes.
4. Chilled water coils are only available in 4, 6, 8 rows.
5. Hot water coils are only available in 1, 2, 3, or 4 rows.
6. FCM and VCM can have up to a total of 8 rows of coil.
7. MCM and MTM can have up to a total of 10 rows of coil.

Coil 2																
Unit Size	1 Row								2 Row							
	A		B		C		D		A		B		C		D	
	Inches	mm	Inches	mm	Inches	mm	Inches	mm	Inches	mm	Inches	mm	Inches	mm	Inches	mm
02	13 1/2	343	6 1/4	159	11 1/4	286	16 3/4	425	13 1/4	337	6 1/4	159	11 1/4	286	16 3/4	425
03	13 1/2	343	6 1/4	159	11 1/4	286	16 3/4	425	13 1/4	337	6 1/4	159	11 1/4	286	16 3/4	425
04	13 1/2	343	6 1/2	165	11 1/4	286	17	432	13 1/4	337	6 1/2	165	11 1/4	286	17	432
06	13 1/2	343	6 1/2	165	11 1/4	286	24 1/2	622	13 1/4	337	6 1/2	165	11 1/4	286	24 1/2	622
08	13 1/2	343	6 3/4	171	11 1/4	286	29 3/4	756	13 1/4	337	6 3/4	171	11 1/4	286	29 3/4	756
10	13 1/2	343	6 1/2	165	11 1/4	286	29 1/2	749	13 1/4	337	6 1/2	165	11 1/4	286	29 1/2	749
12	13 1/2	343	7 1/4	184	11 1/4	286	35 1/4	895	13 1/4	337	7 1/4	184	11 1/4	286	35 1/4	895
14	13 1/2	343	7 1/4	184	11 1/4	286	37 3/4	959	13 1/4	337	7 1/4	184	11 1/4	286	37 3/4	959
17	13 1/2	343	7 1/2	191	11 1/4	286	38	965	13 1/4	337	7 1/2	191	11 1/4	286	38	965
Unit Size	3 Row								4 Row							
	A		B		C		D		A		B		C		D	
	Inches	mm	Inches	mm	Inches	mm	Inches	mm	Inches	mm	Inches	mm	Inches	mm	Inches	mm
02	14 1/4	362	6 1/4	159	12	305	16 3/4	425	15 1/4	387	6 1/4	159	12 1/4	311	16 3/4	425
03	14 1/4	362	6 1/4	159	12	305	16 3/4	425	15 1/4	387	6 1/4	159	12 1/4	311	16 3/4	425
04	14 1/4	362	6 1/2	165	12	305	17	432	15 1/4	387	6 1/2	165	12 1/4	311	17	432
06	14 1/4	362	6 1/2	165	12	305	24 1/2	622	15 1/4	387	6 1/2	165	12 1/4	311	24 1/2	622
08	14 1/4	362	6 3/4	171	12	305	29 3/4	756	15 1/4	387	6 3/4	171	12 1/4	311	29 3/4	756
10	14 1/4	362	6 1/2	165	12	305	29 1/2	749	15 1/4	387	6 1/2	165	12 1/4	311	29 1/2	749
12	14 1/4	362	7 1/4	184	12	305	35 1/4	895	15 1/4	387	7 1/4	184	12 1/4	311	35 1/4	895
14	14 1/4	362	7 1/4	184	12	305	37 3/4	959	15 1/4	387	7 1/4	184	12 1/4	311	37 3/4	959
17	14 1/4	362	7 1/2	191	12	305	38	965	15 1/4	387	7 1/2	191	12 1/4	311	38	965

SBM

6 Row CW Coil w/ HW Reheat Coil Connection Locations

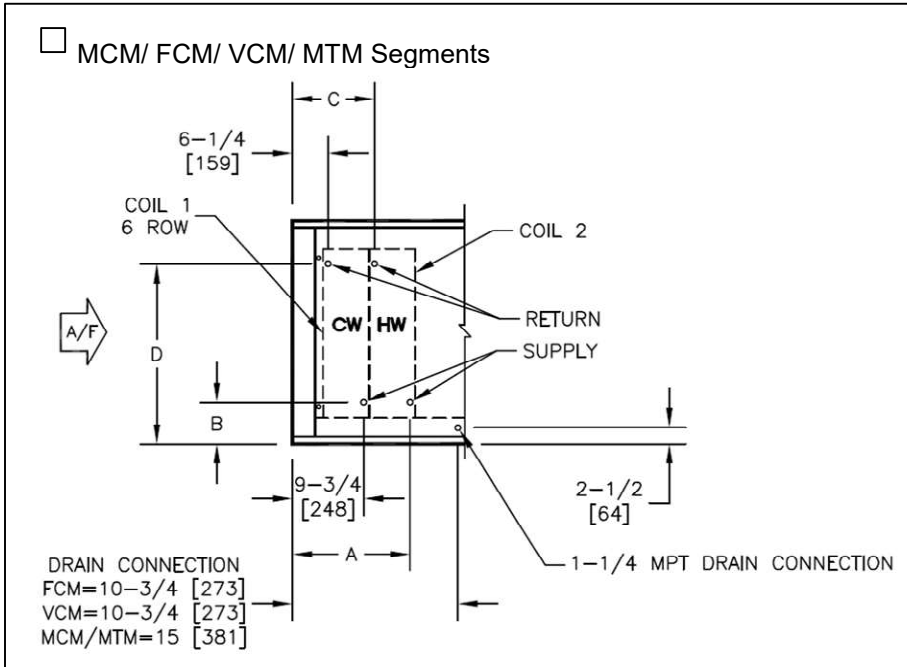

Notes:

1. All Dimensions are inches. All dimensions are +/-1/8" [3mm]. All metric values are rounded to the nearest millimeter.
2. All drawings subject to change without prior notice.
3. See selection program for connection sizes.
4. Chilled water coils are only available in 4 or 6 rows.
5. Hot water coils are only available in 1, 2, 3, or 4 rows.
6. FCM and VCM can have up to a total of 8 rows of coil.
7. MCM and MTM can have up to a total of 10 rows of coil.

Coil 2																
Unit Size	1 Row								2 Row							
	A		B		C		D		A		B		C		D	
	Inches	mm	Inches	mm	Inches	mm	Inches	mm	Inches	mm	Inches	mm	Inches	mm	Inches	mm
02	14 1/2	369	6 1/4	159	12 1/4	312	16 3/4	425	14 1/4	362	6 1/4	159	12 1/4	312	16 3/4	425
03	14 1/2	369	6 1/4	159	12 1/4	312	16 3/4	425	14 1/4	362	6 1/4	159	12 1/4	312	16 3/4	425
04	14 1/2	369	6 1/2	165	12 1/4	312	17	432	14 1/4	362	6 1/2	165	12 1/4	312	17	432
06	14 1/2	369	6 1/2	165	12 1/4	312	24 1/2	622	14 1/4	362	6 1/2	165	12 1/4	312	24 1/2	622
08	14 1/2	369	6 3/4	171	12 1/4	312	29 3/4	756	14 1/4	362	6 3/4	171	12 1/4	312	29 3/4	756
10	14 1/2	369	6 1/2	165	12 1/4	312	29 1/2	749	14 1/4	362	6 1/2	165	12 1/4	312	29 1/2	749
12	14 1/2	369	7 1/4	184	12 1/4	312	35 1/4	895	14 1/4	362	7 1/4	184	12 1/4	312	35 1/4	895
14	14 1/2	369	7 1/4	184	12 1/4	312	37 3/4	959	14 1/4	362	7 1/4	184	12 1/4	312	37 3/4	959
17	14 1/2	369	7 1/2	191	12 1/4	312	38	965	14 1/4	362	7 1/2	191	12 1/4	312	38	965

Unit Size	3 Row								4 Row							
	A		B		C		D		A		B		C		D	
	Inches	mm	Inches	mm	Inches	mm	Inches	mm	Inches	mm	Inches	mm	Inches	mm	Inches	mm
02	15 1/4	388	6 1/4	159	13	331	16 3/4	425	16 1/4	413	6 1/4	159	13 1/4	337	16 3/4	425
03	15 1/4	388	6 1/4	159	13	331	16 3/4	425	16 1/4	413	6 1/4	159	13 1/4	337	16 3/4	425
04	15 1/4	388	6 1/2	165	13	331	17	432	16 1/4	413	6 1/2	165	13 1/4	337	17	432
06	15 1/4	388	6 1/2	165	13	331	24 1/2	622	16 1/4	413	6 1/2	165	13 1/4	337	24 1/2	622
08	15 1/4	388	6 3/4	171	13	331	29 3/4	756	16 1/4	413	6 3/4	171	13 1/4	337	29 3/4	756
10	15 1/4	388	6 1/2	165	13	331	29 1/2	749	16 1/4	413	6 1/2	165	13 1/4	337	29 1/2	749
12	15 1/4	388	7 1/4	184	13	331	35 1/4	895	16 1/4	413	7 1/4	184	13 1/4	337	35 1/4	895
14	15 1/4	388	7 1/4	184	13	331	37 3/4	959	16 1/4	413	7 1/4	184	13 1/4	337	37 3/4	959
17	15 1/4	388	7 1/2	191	13	331	38	965	16 1/4	413	7 1/2	191	13 1/4	337	38	965

SBM

8 Row CW Coil w/ HW Reheat Coil Connection Locations

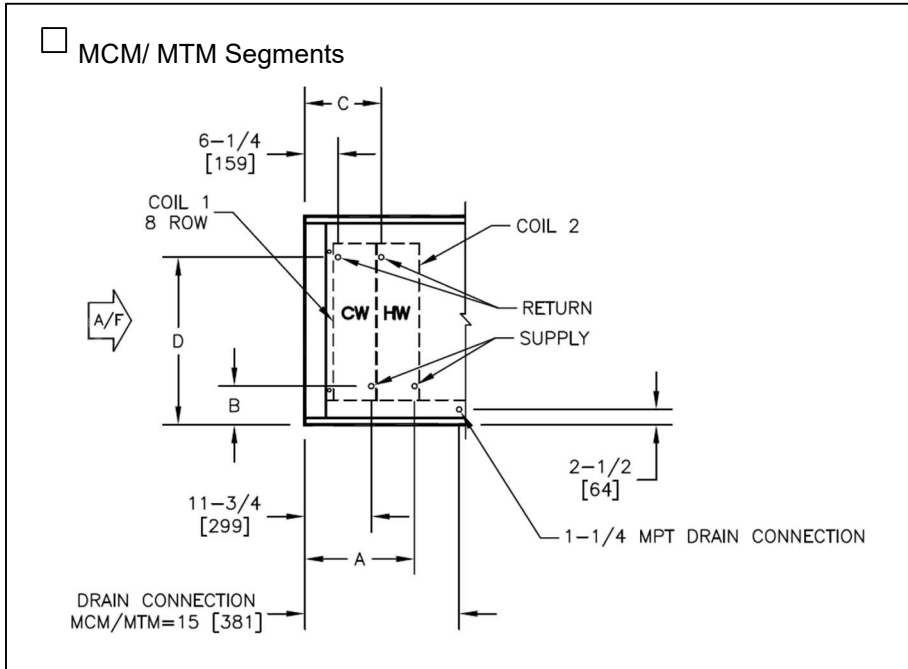

Notes:

1. All Dimensions are inches. All dimensions are +/-1/8" [3mm]. All metric values are rounded to the nearest millimeter.
2. All drawings subject to change without prior notice.
3. See selection program for connection sizes.
4. Chilled water coils are only available in 4 or 6 rows.
5. Hot water coils are only available in 1, 2, 3, or 4 rows.
6. FCM and VCM can have up to a total of 8 rows of coil.
7. MCM and MTM can have up to a total of 10 rows of coil.

		Coil 2															
		1 Row								2 Row							
Unit Size	A		B		C		D		A		B		C		D		
	Inches	mm	Inches	mm	Inches	mm	Inches	mm	Inches	mm	Inches	mm	Inches	mm	Inches	mm	
02	16 1/2	420	6 1/4	159	14 1/4	362	16 3/4	425	16 1/4	413	6 1/4	159	14 1/4	362	16 3/4	425	
03	16 1/2	420	6 1/4	159	14 1/4	362	16 3/4	425	16 1/4	413	6 1/4	159	14 1/4	362	16 3/4	425	
04	16 1/2	420	6 1/2	165	14 1/4	362	17	432	16 1/4	413	6 1/2	165	14 1/4	362	17	432	
06	16 1/2	420	6 1/2	165	14 1/4	362	24 1/2	622	16 1/4	413	6 1/2	165	14 1/4	362	24 1/2	622	
08	16 1/2	420	6 3/4	171	14 1/4	362	29 3/4	756	16 1/4	413	6 3/4	171	14 1/4	362	29 3/4	756	
10	16 1/2	420	6 1/2	165	14 1/4	362	29 1/2	749	16 1/4	413	6 1/2	165	14 1/4	362	29 1/2	749	
12	16 1/2	420	7 1/4	184	14 1/4	362	35 1/4	895	16 1/4	413	7 1/4	184	14 1/4	362	35 1/4	895	
14	16 1/2	420	7 1/4	184	14 1/4	362	37 3/4	959	16 1/4	413	7 1/4	184	14 1/4	362	37 3/4	959	
17	16 1/2	420	7 1/2	191	14 1/4	362	38	965	16 1/4	413	7 1/2	191	14 1/4	362	38	965	

SBM

Single Direct Expansion Coil Connection Locations

☐ MCM/ FCM/ VCM Segments

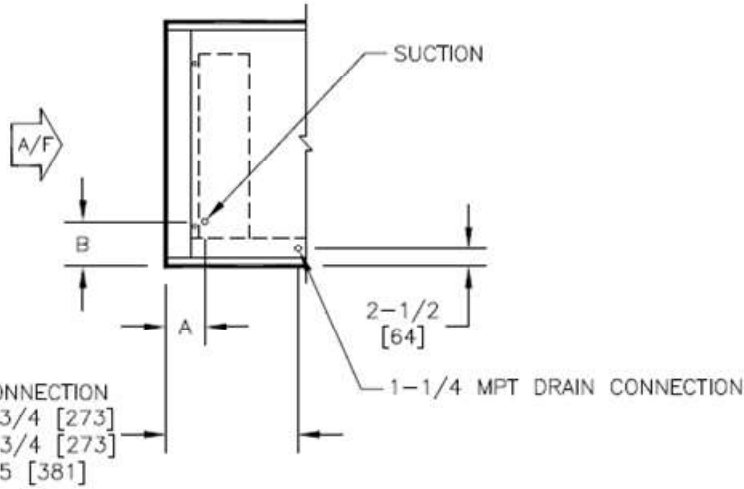

Notes:

1. All Dimensions are inches. All dimensions are +/-1/8" [3mm]. All metric values are rounded to the nearest millimeter.
2. All drawings subject to change without prior notice.
3. Liquid line connections is located inside of cabinet. Field penetration of cabinet is required.
4. See selection program for connection sizes.
5. Direct expansion coils are only available in 3, 4, 6, 8 rows.
6. FCM and VCM can have up to a total of 8 rows of coil.
7. MCM can have up to a total of 10 rows of coil.

Single DX Coil																
Unit Size	3 Row				4 Row				6 Row				8 Row			
	A		B		A		B		A		B		A		B	
	Inches	mm	Inches	mm	Inches	mm	Inches	mm	Inches	mm	Inches	mm	Inches	mm	Inches	mm
02	6	153	6 1/4	159	6	153	16 3/4	425	5 1/2	140	6 1/4	159	5 1/2	140	16 3/4	425
03	6	153	6 1/4	159	6	153	16 3/4	425	5 1/2	140	6 1/4	159	5 1/2	140	16 3/4	425
04	6	153	6 1/2	165	6	153	17	432	5 1/2	140	6 1/2	165	5 1/2	140	17	432
06	6	153	6 1/2	165	6	153	24 1/2	622	5 1/2	140	6 1/2	165	5 1/2	140	24 1/2	622
08	6	153	6 3/4	171	6	153	29 3/4	756	5 1/2	140	6 3/4	171	5 1/2	140	29 3/4	756
10	6	153	6 1/2	165	6	153	29 1/2	749	5 1/2	140	6 1/2	165	5 1/2	140	29 1/2	749
12	6	153	7 1/4	184	6	153	35 1/4	895	5 1/2	140	7 1/4	184	5 1/2	140	35 1/4	895
14	6	153	7 1/4	184	6	153	37 3/4	959	5 1/2	140	7 1/4	184	5 1/2	140	37 3/4	959
17	6	153	7 1/2	191	6	153	38	965	5 1/2	140	7 1/2	191	5 1/2	140	38	965

SBM

1 Row HW Preheat w/ Coil 2 Direct Expansion Coil Connection Locations

☐ MCM/ FCM/ VCM/ MTM Segments

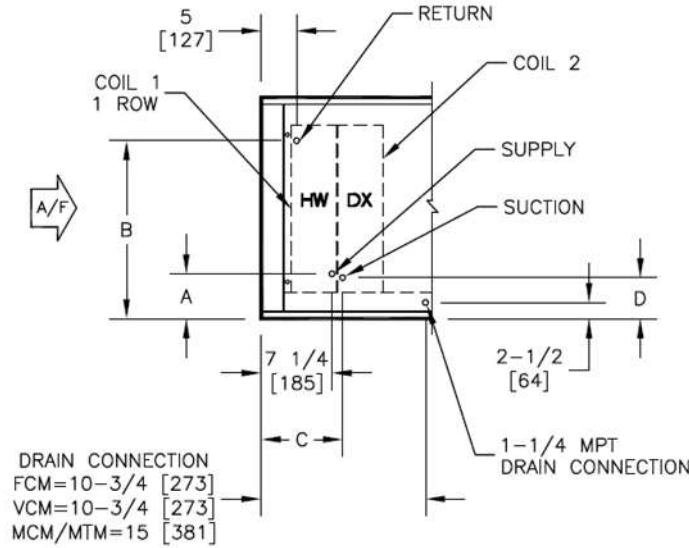

Notes:

1. All Dimensions are inches. All dimensions are +/-1/8" [3mm]. All metric values are rounded to the nearest millimeter.
2. All drawings subject to change without prior notice.
3. Liquid line connections is located inside of cabinet. Field penetration of cabinet is required.
4. See selection program for connection sizes.
5. Direct expansion coils are only available in 3, 4, 6, 8 rows.
6. Hot water coils are only available in 1, 2, 3, 4 rows.
7. FCM and VCM can have up to a total of 8 rows of coil.
8. MCM and MTM can have up to a total of 10 rows of coil.

Coil 2																
Unit Size	3 Row								4 Row							
	A		B		C		D		A		B		C		D	
	Inches	mm	Inches	mm	Inches	mm	Inches	mm	Inches	mm	Inches	mm	Inches	mm	Inches	mm
02	6 1/4	159	16 3/4	425	9 1/2	241	4 1/4	108	6 1/4	159	16 3/4	425	9 1/2	241	5	127
03	6 1/4	159	16 3/4	425	9 1/2	241	4 1/4	108	6 1/4	159	16 3/4	425	9 1/2	241	5	127
04	6 1/2	165	17	432	9 1/2	241	4 3/4	121	6 1/2	165	17	432	9 1/2	241	5 1/4	134
06	6 1/2	165	24 1/2	622	9 1/2	241	4 3/4	121	6 1/2	165	24 1/2	622	9 1/2	241	5 1/2	140
08	6 3/4	171	29 3/4	756	9 1/2	241	4 3/4	121	6 3/4	171	29 3/4	756	9 1/2	241	5 1/2	140
10	6 1/2	165	29 1/2	749	9 1/2	241	4 3/4	121	6 1/2	165	29 1/2	749	9 1/2	241	5 1/2	140
12	7 1/4	184	35 1/4	895	9 1/2	241	5 3/4	147	7 1/4	184	35 1/4	895	9 1/2	241	6 1/4	159
14	7 1/4	184	37 3/4	959	9 1/2	241	5 3/4	147	7 1/4	184	37 3/4	959	9 1/2	241	6 1/2	166
17	7 1/2	191	38	965	9 1/2	241	6	153	7 1/2	191	38	965	9 1/2	241	6 3/4	172

Unit Size	6 Row								8 Row							
	A		B		C		D		A		B		C		D	
	Inches	mm	Inches	mm	Inches	mm	Inches	mm	Inches	mm	Inches	mm	Inches	mm	Inches	mm
02	6 1/4	159	16 3/4	425	9	229	5	127	6 1/4	159	16 3/4	425	9	229	5	127
03	6 1/4	159	16 3/4	425	9	229	5	127	6 1/4	159	16 3/4	425	9	229	5	127
04	6 1/2	165	17	432	9	229	5 1/4	134	6 1/2	165	17	432	9	229	5 1/2	140
06	6 1/2	165	24 1/2	622	9	229	6 3/4	172	6 1/2	165	24 1/2	622	9	229	5 1/2	140
08	6 3/4	171	29 3/4	756	9	229	5 1/2	140	6 3/4	171	29 3/4	756	9	229	5 1/2	140
10	6 1/2	165	29 1/2	749	9	229	5 1/2	140	6 1/2	165	29 1/2	749	9	229	5 1/2	140
12	7 1/4	184	35 1/4	895	9	229	6 1/2	166	7 1/4	184	35 1/4	895	9	229	6 1/4	159
14	7 1/4	184	37 3/4	959	9	229	7 1/2	191	7 1/4	184	37 3/4	959	9	229	7 3/4	197
17	7 1/2	191	38	965	9	229	8	204	7 1/2	191	38	965	9	229	7	178

SBM

2 Row HW Preheat w/ Coil 2 Direct Expansion Coil Connection Locations

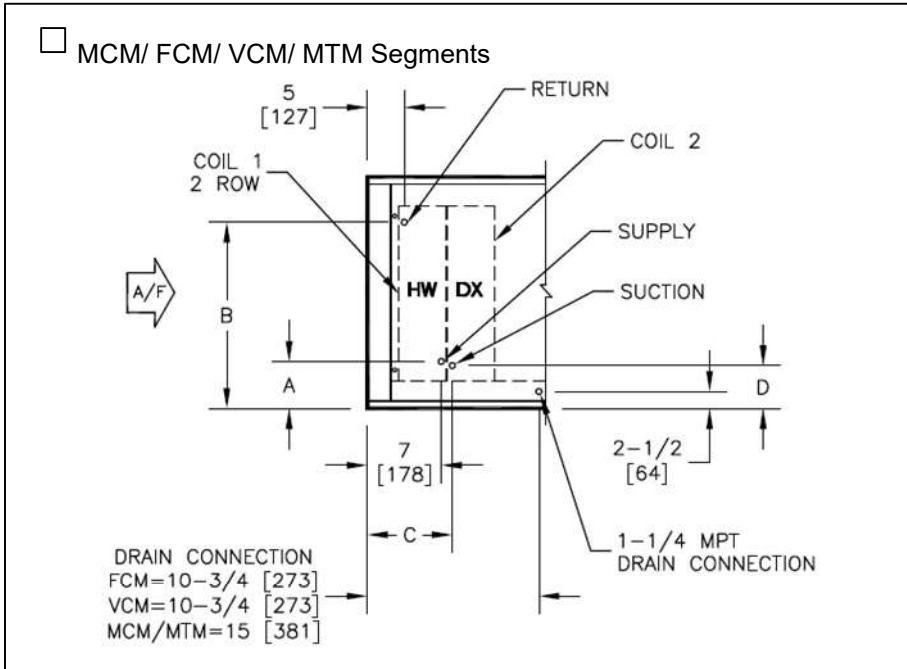

Notes:

1. All Dimensions are inches. All dimensions are +/-1/8" [3mm]. All metric values are rounded to the nearest millimeter.
2. All drawings subject to change without prior notice.
3. Liquid line connections is located inside of cabinet. Field penetration of cabinet is required.
4. See selection program for connection sizes.
5. Direct expansion coils are only available in 3, 4, 6, 8 rows.
6. Hot water coils are only available in 1, 2, 3, 4 rows.
7. FCM and VCM can have up to a total of 8 rows of coil.
8. MCM and MTM can have up to a total of 10 rows of coil.

Coil 2																
Unit Size	3 Row								4 Row							
	A		B		C		D		A		B		C		D	
	Inches	mm	Inches	mm	Inches	mm	Inches	mm	Inches	mm	Inches	mm	Inches	mm	Inches	mm
02	6 1/4	159	16 3/4	425	9 1/4	235	4 1/4	108	6 1/4	159	16 3/4	425	9 1/4	235	5	127
03	6 1/4	159	16 3/4	425	9 1/4	235	4 1/4	108	6 1/4	159	16 3/4	425	9 1/4	235	5	127
04	6 1/2	165	17	432	9 1/4	235	4 3/4	121	6 1/2	165	17	432	9 1/4	235	5 1/4	134
06	6 1/2	165	24 1/2	622	9 1/4	235	4 3/4	121	6 1/2	165	24 1/2	622	9 1/4	235	5 1/2	140
08	6 3/4	171	29 3/4	756	9 1/4	235	4 3/4	121	6 3/4	171	29 3/4	756	9 1/4	235	5 1/2	140
10	6 1/2	165	29 1/2	749	9 1/4	235	4 3/4	121	6 1/2	165	29 1/2	749	9 1/4	235	5 1/2	140
12	7 1/4	184	35 1/4	895	9 1/4	235	5 3/4	147	7 1/4	184	35 1/4	895	9 1/4	235	6 1/4	159
14	7 1/4	184	37 3/4	959	9 1/4	235	5 3/4	147	7 1/4	184	37 3/4	959	9 1/4	235	6 1/2	166
17	7 1/2	191	38	965	9 1/4	235	6	153	7 1/2	191	38	965	9 1/4	235	6 3/4	172

Unit Size	6 Row								8 Row							
	A		B		C		D		A		B		C		D	
	Inches	mm	Inches	mm	Inches	mm	Inches	mm	Inches	mm	Inches	mm	Inches	mm	Inches	mm
02	6 1/4	159	16 3/4	425	8 3/4	223	5	127	6 1/4	159	16 3/4	425	8 3/4	223	5	127
03	6 1/4	159	16 3/4	425	8 3/4	223	5	127	6 1/4	159	16 3/4	425	8 3/4	223	5	127
04	6 1/2	165	17	432	8 3/4	223	5 1/4	134	6 1/2	165	17	432	8 3/4	223	5 1/2	140
06	6 1/2	165	24 1/2	622	8 3/4	223	6 3/4	172	6 1/2	165	24 1/2	622	8 3/4	223	5 1/2	140
08	6 3/4	171	29 3/4	756	8 3/4	223	5 1/2	140	6 3/4	171	29 3/4	756	8 3/4	223	5 1/2	140
10	6 1/2	165	29 1/2	749	8 3/4	223	5 1/2	140	6 1/2	165	29 1/2	749	8 3/4	223	5 1/2	140
12	7 1/4	184	35 1/4	895	8 3/4	223	6 1/2	166	7 1/4	184	35 1/4	895	8 3/4	223	6 1/4	159
14	7 1/4	184	37 3/4	959	8 3/4	223	7 1/2	191	7 1/4	184	37 3/4	959	8 3/4	223	7 3/4	197
17	7 1/2	191	38	965	8 3/4	223	8	204	7 1/2	191	38	965	8 3/4	223	7	178

SBM

3 Row HW Preheat w/ Coil 2 Direct Expansion Coil Connection Locations

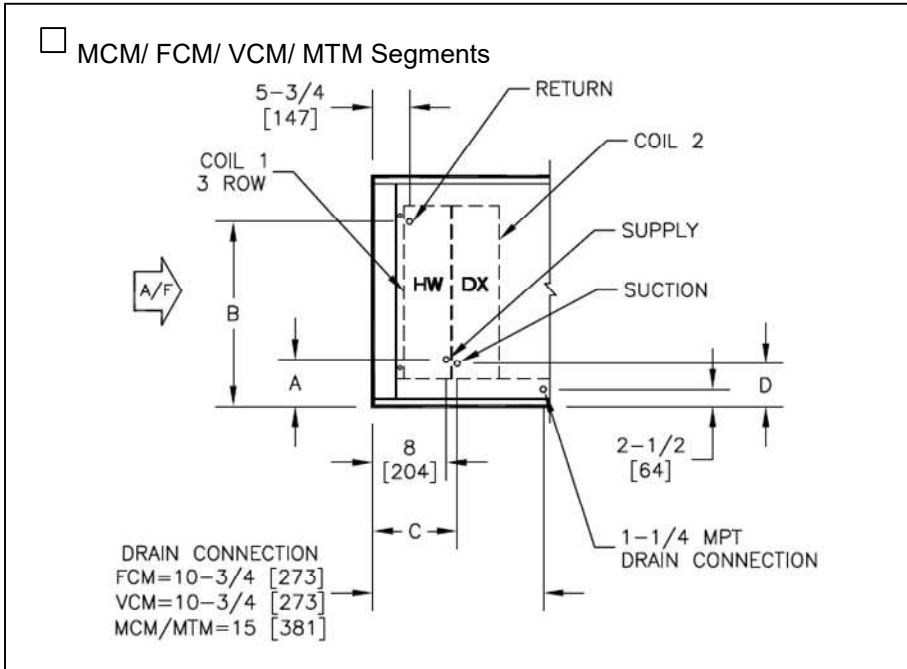

Notes:

1. All Dimensions are inches. All dimensions are +/-1/8" [3mm]. All metric values are rounded to the nearest millimeter.
2. All drawings subject to change without prior notice.
3. Liquid line connections is located inside of cabinet. Field penetration of cabinet is required.
4. See selection program for connection sizes.
5. Direct expansion coils are only available in 3, 4, 6, 8 rows.
6. Hot water coils are only available in 1, 2, 3, 4 rows.
7. FCM and VCM can have up to a total of 8 rows of coil.
8. MCM and MTM can have up to a total of 10 rows of coil.

Coil 2																
Unit Size	3 Row								4 Row							
	A		B		C		D		A		B		C		D	
	Inches	mm	Inches	mm	Inches	mm	Inches	mm	Inches	mm	Inches	mm	Inches	mm	Inches	mm
02	6 1/4	159	16 3/4	425	11	280	4 1/4	108	6 1/4	159	16 3/4	425	11	280	5	127
03	6 1/4	159	16 3/4	425	11	280	4 1/4	108	6 1/4	159	16 3/4	425	11	280	5	127
04	6 1/2	165	17	432	11	280	4 3/4	121	6 1/2	165	17	432	11	280	5 1/4	134
06	6 1/2	165	24 1/2	622	11	280	4 3/4	121	6 1/2	165	24 1/2	622	11	280	5 1/2	140
08	6 3/4	171	29 3/4	756	11	280	4 3/4	121	6 3/4	171	29 3/4	756	11	280	5 1/2	140
10	6 1/2	165	29 1/2	749	11	280	4 3/4	121	6 1/2	165	29 1/2	749	11	280	5 1/2	140
12	7 1/4	184	35 1/4	895	11	280	5 3/4	147	7 1/4	184	35 1/4	895	11	280	6 1/4	159
14	7 1/4	184	37 3/4	959	11	280	5 3/4	147	7 1/4	184	37 3/4	959	11	280	6 1/2	166
17	7 1/2	191	38	965	11	280	6	153	7 1/2	191	38	965	11	280	6 3/4	172

Coil 2								
Unit Size	6 Row							
	A		B		C		D	
	Inches	mm	Inches	mm	Inches	mm	Inches	mm
02	6 1/4	159	16 3/4	425	10 1/2	267	5	127
03	6 1/4	159	16 3/4	425	10 1/2	267	5	127
04	6 1/2	165	17	432	10 1/2	267	5 1/4	134
06	6 1/2	165	24 1/2	622	10 1/2	267	6 3/4	172
08	6 3/4	171	29 3/4	756	10 1/2	267	5 1/2	140
10	6 1/2	165	29 1/2	749	10 1/2	267	5 1/2	140
12	7 1/4	184	35 1/4	895	10 1/2	267	6 1/2	166
14	7 1/4	184	37 3/4	959	10 1/2	267	7 1/2	191
17	7 1/2	191	38	965	10 1/2	267	8	204

SBM

4 Row HW Preheat w/ Coil 2 Direct Expansion Coil Connection Locations

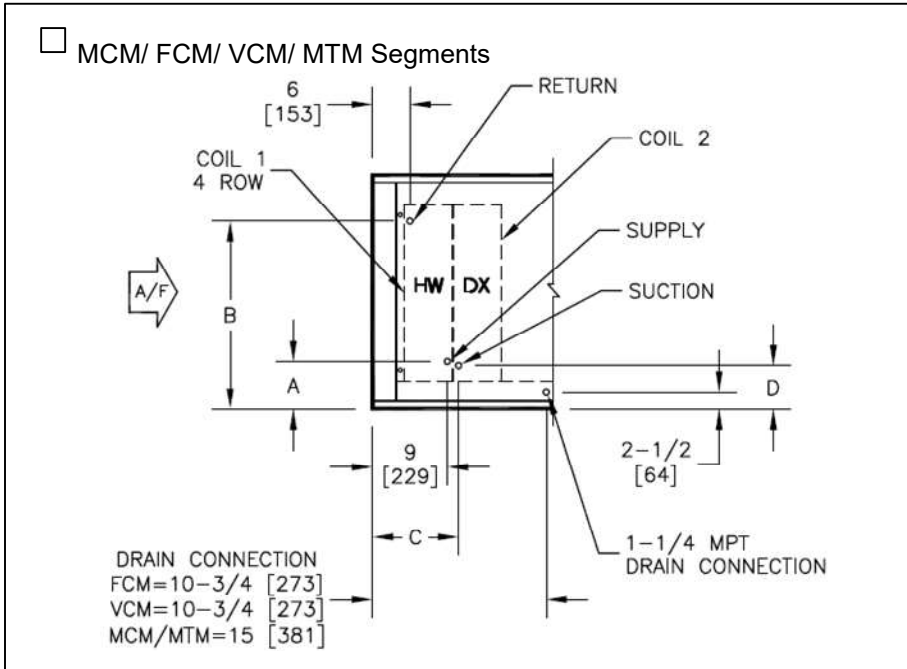

Notes:

1. All Dimensions are inches. All dimensions are +/-1/8" [3mm]. All metric values are rounded to the nearest millimeter.
2. All drawings subject to change without prior notice.
3. Liquid line connections is located inside of cabinet. Field penetration of cabinet is required.
4. See selection program for connection sizes.
5. Direct expansion coils are only available in 3, 4, 6, 8 rows.
6. Hot water coils are only available in 1, 2, 3, 4 rows.
7. FCM and VCM can have up to a total of 8 rows of coil.
8. MCM and MTM can have up to a total of 10 rows of coil.

Coil 2

Unit Size	3 Row								4 Row							
	A		B		C		D		A		B		C		D	
	Inches	mm	Inches	mm	Inches	mm	Inches	mm	Inches	mm	Inches	mm	Inches	mm	Inches	mm
02	6 1/4	159	16 3/4	425	12 1/4	312	4 1/4	108	6 1/4	159	16 3/4	425	12 1/4	312	5	127
03	6 1/4	159	16 3/4	425	12 1/4	312	4 1/4	108	6 1/4	159	16 3/4	425	12 1/4	312	5	127
04	6 1/2	165	17	432	12 1/4	312	4 3/4	121	6 1/2	165	17	432	12 1/4	312	5 1/4	134
06	6 1/2	165	24 1/2	622	12 1/4	312	4 3/4	121	6 1/2	165	24 1/2	622	12 1/4	312	5 1/2	140
08	6 3/4	171	29 3/4	756	12 1/4	312	4 3/4	121	6 3/4	171	29 3/4	756	12 1/4	312	5 1/2	140
10	6 1/2	165	29 1/2	749	12 1/4	312	4 3/4	121	6 1/2	165	29 1/2	749	12 1/4	312	5 1/2	140
12	7 1/4	184	35 1/4	895	12 1/4	312	5 3/4	147	7 1/4	184	35 1/4	895	12 1/4	312	6 1/4	159
14	7 1/4	184	37 3/4	959	12 1/4	312	5 3/4	147	7 1/4	184	37 3/4	959	12 1/4	312	6 1/2	166
17	7 1/2	191	38	965	12 1/4	312	6	153	7 1/2	191	38	965	12 1/4	312	6 3/4	172

Coil 2

Unit Size	6 Row							
	A		B		C		D	
	Inches	mm	Inches	mm	Inches	mm	Inches	mm
02	6 1/4	159	16 3/4	425	11 3/4	299	5	127
03	6 1/4	159	16 3/4	425	11 3/4	299	5	127
04	6 1/2	165	17	432	11 3/4	299	5 1/4	134
06	6 1/2	165	24 1/2	622	11 3/4	299	6 3/4	172
08	6 3/4	171	29 3/4	756	11 3/4	299	5 1/2	140
10	6 1/2	165	29 1/2	749	11 3/4	299	5 1/2	140
12	7 1/4	184	35 1/4	895	11 3/4	299	6 1/2	166
14	7 1/4	184	37 3/4	959	11 3/4	299	7 1/2	191
17	7 1/2	191	38	965	11 3/4	299	8	204

SBM

3 Row Direct Expansion and HW Reheat Coil Connection Locations

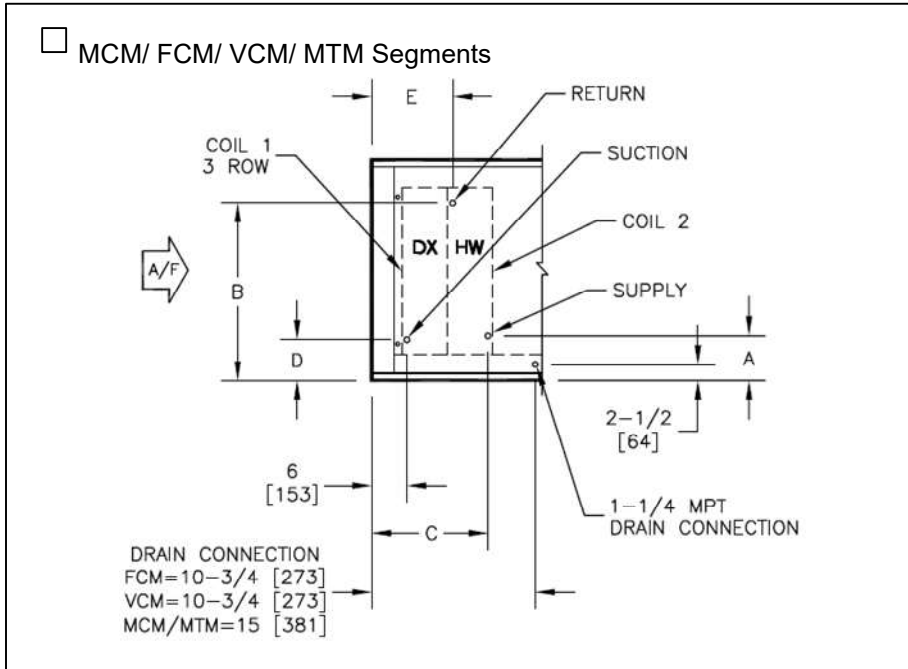

Notes:

1. All Dimensions are inches. All dimensions are +/-1/8" [3mm]. All metric values are rounded to the nearest millimeter.
2. All drawings subject to change without prior notice.
3. Liquid line connections is located inside of cabinet. Field penetration of cabinet is required.
4. See selection program for connection sizes.
5. Direct expansion coils are only available in 3, 4, 6, 8 rows.
6. Hot water coils are only available in 1, 2, 3, 4 rows.
7. FCM and VCM can have up to a total of 8 rows of coil.
8. MCM and MTM can have up to a total of 10 rows of coil.

Coil 2																				
Unit Size	1 Row										2 Row									
	A		B		C		D		E		A		B		C		D		E	
	Inches	mm	Inches	mm	Inches	mm	Inches	mm	Inches	mm	Inches	mm	Inches	mm	Inches	mm	Inches	mm	Inches	mm
02	6 1/4	159	16 3/4	425	12 1/4	312	4 1/4	108	10	254	6 1/4	159	16 3/4	425	12	305	4 1/4	108	10	254
03	6 1/4	159	16 3/4	425	12 1/4	312	4 1/4	108	10	254	6 1/4	159	16 3/4	425	12	305	4 1/4	108	10	254
04	6 1/2	165	17	432	12 1/4	312	4 3/4	121	10	254	6 1/2	165	17	432	12	305	4 3/4	121	10	254
06	6 1/2	165	24 1/2	622	12 1/4	312	4 3/4	121	10	254	6 1/2	165	24 1/2	622	12	305	4 3/4	121	10	254
08	6 3/4	171	29 3/4	756	12 1/4	312	4 3/4	121	10	254	6 3/4	171	29 3/4	756	12	305	4 3/4	121	10	254
10	6 1/2	165	29 1/2	749	12 1/4	312	4 3/4	121	10	254	6 1/2	165	29 1/2	749	12	305	4 3/4	121	10	254
12	7 1/4	184	35 1/4	895	12 1/4	312	5 3/4	147	10	254	7 1/4	184	35 1/4	895	12	305	5 3/4	147	10	254
14	7 1/4	184	37 3/4	959	12 1/4	312	5 3/4	147	10	254	7 1/4	184	37 3/4	959	12	305	5 3/4	147	10	254
17	7 1/2	191	38	965	12 1/4	312	6	153	10	254	7 1/2	191	38	965	12	305	6	153	10	254

Unit Size	3 Row										4 Row									
	A		B		C		D		E		A		B		C		D		E	
	Inches	mm	Inches	mm	Inches	mm	Inches	mm	Inches	mm	Inches	mm	Inches	mm	Inches	mm	Inches	mm	Inches	mm
02	6 1/4	159	16 3/4	425	13	331	4 1/4	108	10 3/4	274	6 1/4	159	16 3/4	425	14	356	4 1/4	108	11	280
03	6 1/4	159	16 3/4	425	13	331	4 1/4	108	10 3/4	274	6 1/4	159	16 3/4	425	14	356	4 1/4	108	11	280
04	6 1/2	165	17	432	13	331	4 3/4	121	10 3/4	274	6 1/2	165	17	432	14	356	4 3/4	121	11	280
06	6 1/2	165	24 1/2	622	13	331	4 3/4	121	10 3/4	274	6 1/2	165	24 1/2	622	14	356	4 3/4	121	11	280
08	6 3/4	171	29 3/4	756	13	331	4 3/4	121	10 3/4	274	6 3/4	171	29 3/4	756	14	356	4 3/4	121	11	280
10	6 1/2	165	29 1/2	749	13	331	4 3/4	121	10 3/4	274	6 1/2	165	29 1/2	749	14	356	4 3/4	121	11	280
12	7 1/4	184	35 1/4	895	13	331	5 3/4	147	10 3/4	274	7 1/4	184	35 1/4	895	14	356	5 3/4	147	11	280
14	7 1/4	184	37 3/4	959	13	331	5 3/4	147	10 3/4	274	7 1/4	184	37 3/4	959	14	356	5 3/4	147	11	280
17	7 1/2	191	38	965	13	331	6	153	10 3/4	274	7 1/2	191	38	965	14	356	6	153	11	280

SBM

4 Row Direct Expansion and HW Reheat Coil Connection Locations

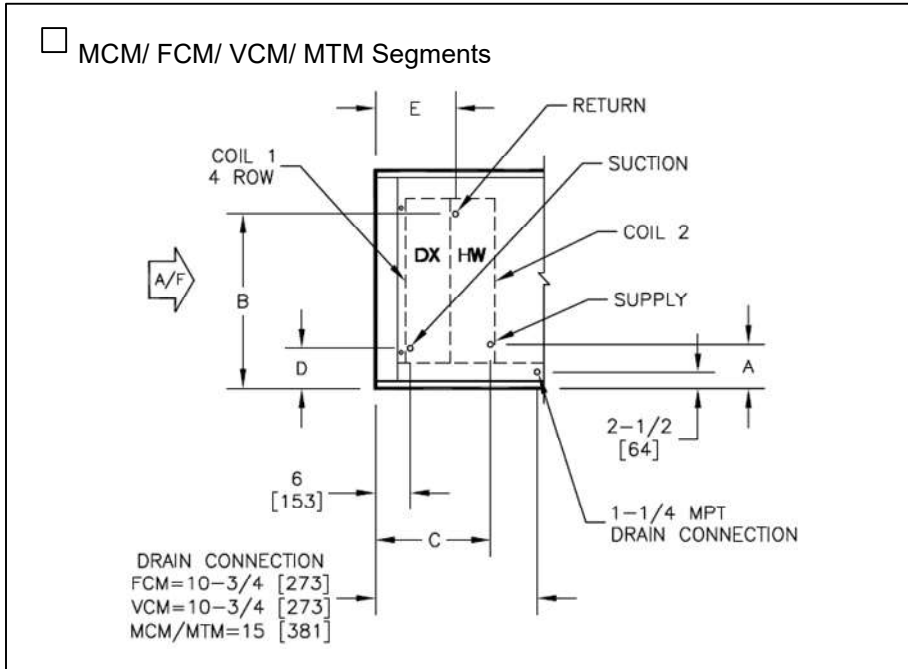

Notes:

1. All Dimensions are inches. All dimensions are +/-1/8" [3mm]. All metric values are rounded to the nearest millimeter.
2. All drawings subject to change without prior notice.
3. Liquid line connections is located inside of cabinet. Field penetration of cabinet is required.
4. See selection program for connection sizes.
5. Direct expansion coils are only available in 3, 4, 6, 8 rows.
6. Hot water coils are only available in 1, 2, 3, 4 rows.
7. FCM and VCM can have up to a total of 8 rows of coil.
8. MCM and MTM can have up to a total of 10 rows of coil.

Coil 2																					
Unit Size	1 Row										2 Row										
	A		B		C		D		E		A		B		C		D		E		
	Inches	mm	Inches	mm	Inches	mm	Inches	mm	Inches	mm	Inches	mm	Inches	mm	Inches	mm	Inches	mm	Inches	mm	
02	6 1/4	159	16 3/4	425	13 1/2	343	4 1/4	108	11 1/4	286	6 1/4	159	16 3/4	425	13 1/4	337	4 1/4	108	11 1/4	286	
03	6 1/4	159	16 3/4	425	13 1/2	343	4 1/4	108	11 1/4	286	6 1/4	159	16 3/4	425	13 1/4	337	4 1/4	108	11 1/4	286	
04	6 1/2	165	17	432	13 1/2	343	4 3/4	121	11 1/4	286	6 1/2	165	17	432	13 1/4	337	4 3/4	121	11 1/4	286	
06	6 1/2	165	24 1/2	622	13 1/2	343	4 3/4	121	11 1/4	286	6 1/2	165	24 1/2	622	13 1/4	337	4 3/4	121	11 1/4	286	
08	6 3/4	171	29 3/4	756	13 1/2	343	4 3/4	121	11 1/4	286	6 3/4	171	29 3/4	756	13 1/4	337	4 3/4	121	11 1/4	286	
10	6 1/2	165	29 1/2	749	13 1/2	343	4 3/4	121	11 1/4	286	6 1/2	165	29 1/2	749	13 1/4	337	4 3/4	121	11 1/4	286	
12	7 1/4	184	35 1/4	895	13 1/2	343	5 3/4	147	11 1/4	286	7 1/4	184	35 1/4	895	13 1/4	337	5 3/4	147	11 1/4	286	
14	7 1/4	184	37 3/4	959	13 1/2	343	5 3/4	147	11 1/4	286	7 1/4	184	37 3/4	959	13 1/4	337	5 3/4	147	11 1/4	286	
17	7 1/2	191	38	965	13 1/2	343	6	153	11 1/4	286	7 1/2	191	38	965	13 1/4	337	6	153	11 1/4	286	

Unit Size	3 Row										4 Row									
	A		B		C		D		E		A		B		C		D		E	
	Inches	mm	Inches	mm	Inches	mm	Inches	mm	Inches	mm	Inches	mm	Inches	mm	Inches	mm	Inches	mm	Inches	mm
02	6 1/4	159	16 3/4	425	14 1/4	362	4 1/4	108	12	305	6 1/4	159	16 3/4	425	15 1/4	388	4 1/4	108	12 1/4	312
03	6 1/4	159	16 3/4	425	14 1/4	362	4 1/4	108	12	305	6 1/4	159	16 3/4	425	15 1/4	388	4 1/4	108	12 1/4	312
04	6 1/2	165	17	432	14 1/4	362	4 3/4	121	12	305	6 1/2	165	17	432	15 1/4	388	4 3/4	121	12 1/4	312
06	6 1/2	165	24 1/2	622	14 1/4	362	4 3/4	121	12	305	6 1/2	165	24 1/2	622	15 1/4	388	4 3/4	121	12 1/4	312
08	6 3/4	171	29 3/4	756	14 1/4	362	4 3/4	121	12	305	6 3/4	171	29 3/4	756	15 1/4	388	4 3/4	121	12 1/4	312
10	6 1/2	165	29 1/2	749	14 1/4	362	4 3/4	121	12	305	6 1/2	165	29 1/2	749	15 1/4	388	4 3/4	121	12 1/4	312
12	7 1/4	184	35 1/4	895	14 1/4	362	5 3/4	147	12	305	7 1/4	184	35 1/4	895	15 1/4	388	5 3/4	147	12 1/4	312
14	7 1/4	184	37 3/4	959	14 1/4	362	5 3/4	147	12	305	7 1/4	184	37 3/4	959	15 1/4	388	5 3/4	147	12 1/4	312
17	7 1/2	191	38	965	14 1/4	362	6	153	12	305	7 1/2	191	38	965	15 1/4	388	6	153	12 1/4	312

SBM

6 Row Direct Expansion and HW Reheat Coil Connection Locations

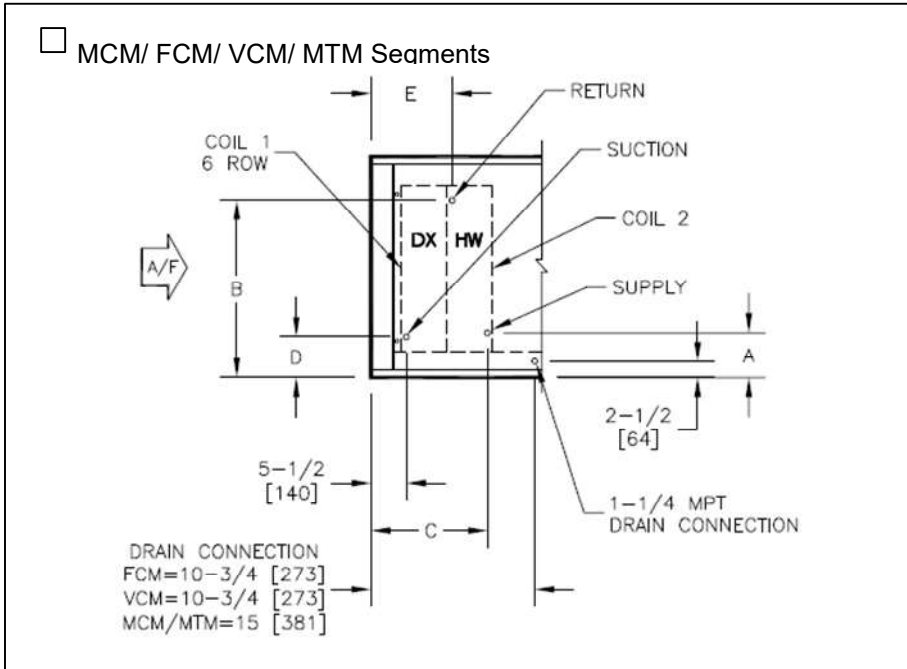

Notes:

1. All Dimensions are inches. All dimensions are +/-1/8" [3mm]. All metric values are rounded to the nearest millimeter.
2. All drawings subject to change without prior notice.
3. Liquid line connections is located inside of cabinet. Field penetration of cabinet is required.
4. See selection program for connection sizes.
5. Direct expansion coils are only available in 3, 4, 6, 8 rows.
6. Hot water coils are only available in 1, 2, 3, 4 rows.
7. FCM and VCM can have up to a total of 8 rows of coil.
8. MCM and MTM can have up to a total of 10 rows of coil.

Coil 2																				
Unit Size	1 Row										2 Row									
	A		B		C		D		E		A		B		C		D		E	
	Inches	mm	Inches	mm	Inches	mm	Inches	mm	Inches	mm	Inches	mm	Inches	mm	Inches	mm	Inches	mm	Inches	mm
02	6 1/4	159	16 3/4	425	14 1/2	369	4 1/4	108	12 1/4	312	6 1/4	159	16 3/4	425	14 1/4	362	4 1/4	108	12 1/4	312
03	6 1/4	159	16 3/4	425	14 1/2	369	4 1/4	108	12 1/4	312	6 1/4	159	16 3/4	425	14 1/4	362	4 1/4	108	12 1/4	312
04	6 1/2	165	17	432	14 1/2	369	4 3/4	121	12 1/4	312	6 1/2	165	17	432	14 1/4	362	4 3/4	121	12 1/4	312
06	6 1/2	165	24 1/2	622	14 1/2	369	4 3/4	121	12 1/4	312	6 1/2	165	24 1/2	622	14 1/4	362	4 3/4	121	12 1/4	312
08	6 3/4	171	29 3/4	756	14 1/2	369	4 3/4	121	12 1/4	312	6 3/4	171	29 3/4	756	14 1/4	362	4 3/4	121	12 1/4	312
10	6 1/2	165	29 1/2	749	14 1/2	369	4 3/4	121	12 1/4	312	6 1/2	165	29 1/2	749	14 1/4	362	4 3/4	121	12 1/4	312
12	7 1/4	184	35 1/4	895	14 1/2	369	5 3/4	147	12 1/4	312	7 1/4	184	35 1/4	895	14 1/4	362	5 3/4	147	12 1/4	312
14	7 1/4	184	37 3/4	959	14 1/2	369	5 3/4	147	12 1/4	312	7 1/4	184	37 3/4	959	14 1/4	362	5 3/4	147	12 1/4	312
17	7 1/2	191	38	965	14 1/2	369	6	153	12 1/4	312	7 1/2	191	38	965	14 1/4	362	6	153	12 1/4	312

Unit Size	3 Row										4 Row									
	A		B		C		D		E		A		B		C		D		E	
	Inches	mm	Inches	mm	Inches	mm	Inches	mm	Inches	mm	Inches	mm	Inches	mm	Inches	mm	Inches	mm	Inches	mm
02	6 1/4	159	16 3/4	425	15 1/4	388	4 1/4	108	13	331	6 1/4	159	16 3/4	425	16 1/4	413	4 1/4	108	13 1/4	337
03	6 1/4	159	16 3/4	425	15 1/4	388	4 1/4	108	13	331	6 1/4	159	16 3/4	425	16 1/4	413	4 1/4	108	13 1/4	337
04	6 1/2	165	17	432	15 1/4	388	4 3/4	121	13	331	6 1/2	165	17	432	16 1/4	413	4 3/4	121	13 1/4	337
06	6 1/2	165	24 1/2	622	15 1/4	388	4 3/4	121	13	331	6 1/2	165	24 1/2	622	16 1/4	413	4 3/4	121	13 1/4	337
08	6 3/4	171	29 3/4	756	15 1/4	388	4 3/4	121	13	331	6 3/4	171	29 3/4	756	16 1/4	413	4 3/4	121	13 1/4	337
10	6 1/2	165	29 1/2	749	15 1/4	388	4 3/4	121	13	331	6 1/2	165	29 1/2	749	16 1/4	413	4 3/4	121	13 1/4	337
12	7 1/4	184	35 1/4	895	15 1/4	388	5 3/4	147	13	331	7 1/4	184	35 1/4	895	16 1/4	413	5 3/4	147	13 1/4	337
14	7 1/4	184	37 3/4	959	15 1/4	388	5 3/4	147	13	331	7 1/4	184	37 3/4	959	16 1/4	413	5 3/4	147	13 1/4	337
17	7 1/2	191	38	965	15 1/4	388	6	153	13	331	7 1/2	191	38	965	16 1/4	413	6	153	13 1/4	337

SBM

8 Row Direct Expansion and HW Reheat Coil Connection Locations

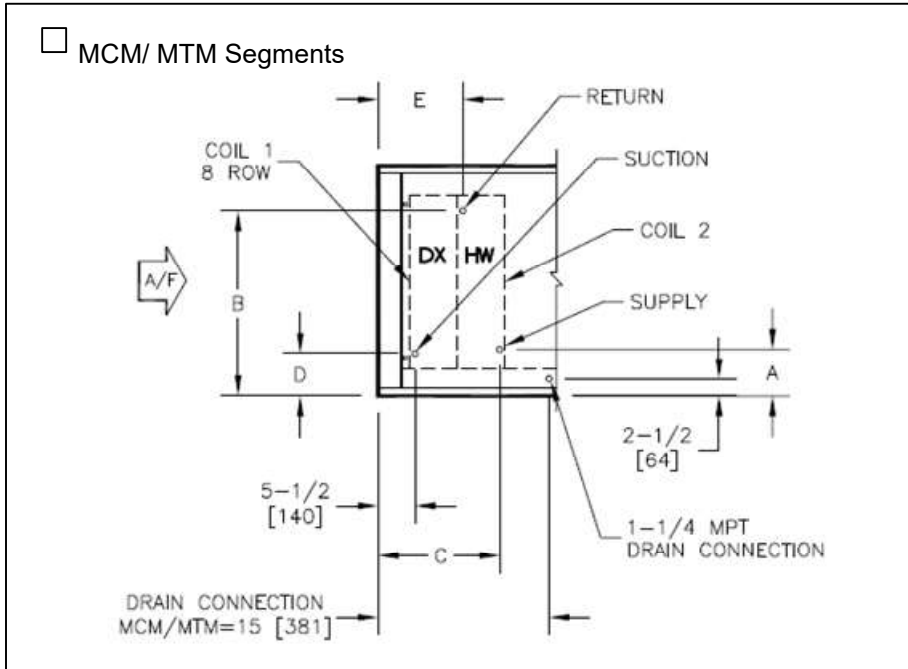

Notes:

1. All Dimensions are inches. All dimensions are +/-1/8" [3mm]. All metric values are rounded to the nearest millimeter.
2. All drawings subject to change without prior notice.
3. Liquid line connections is located inside of cabinet. Field penetration of cabinet is required.
4. See selection program for connection sizes.
5. Direct expansion coils are only available in 3, 4, 6, 8 rows.
6. Hot water coils are only available in 1, 2, 3, 4 rows.
7. MCM and MTM can have up to a total of 10 rows of coil.

Unit Size	Coil 2																			
	1 Row										2 Row									
	A		B		C		D		E		A		B		C		D		E	
	Inches	mm	Inches	mm	Inches	mm	Inches	mm	Inches	mm	Inches	mm	Inches	mm	Inches	mm	Inches	mm	Inches	mm
02	6 1/4	159	16 3/4	425	16 1/2	420	4 1/4	108	14 1/4	362	6 1/4	159	16 3/4	425	16 1/4	413	4 1/4	108	14 1/4	362
03	6 1/4	159	16 3/4	425	16 1/2	420	4 1/4	108	14 1/4	362	6 1/4	159	16 3/4	425	16 1/4	413	4 1/4	108	14 1/4	362
04	6 1/2	165	17	432	16 1/2	420	4 3/4	121	14 1/4	362	6 1/2	165	17	432	16 1/4	413	4 3/4	121	14 1/4	362
06	6 1/2	165	24 1/2	622	16 1/2	420	4 3/4	121	14 1/4	362	6 1/2	165	24 1/2	622	16 1/4	413	4 3/4	121	14 1/4	362
08	6 3/4	171	29 3/4	756	16 1/2	420	4 3/4	121	14 1/4	362	6 3/4	171	29 3/4	756	16 1/4	413	4 3/4	121	14 1/4	362
10	6 1/2	165	29 1/2	749	16 1/2	420	4 3/4	121	14 1/4	362	6 1/2	165	29 1/2	749	16 1/4	413	4 3/4	121	14 1/4	362
12	7 1/4	184	35 1/4	895	16 1/2	420	5 3/4	147	14 1/4	362	7 1/4	184	35 1/4	895	16 1/4	413	5 3/4	147	14 1/4	362
14	7 1/4	184	37 3/4	959	16 1/2	420	5 3/4	147	14 1/4	362	7 1/4	184	37 3/4	959	16 1/4	413	5 3/4	147	14 1/4	362
17	7 1/2	191	38	965	16 1/2	420	6	153	14 1/4	362	7 1/2	191	38	965	16 1/4	413	6	153	14 1/4	362

SBM

4 Row Chilled Water w/ Redundant DX Cooling Coil Connection Locations

MCM/ FCM/ VCM Segments

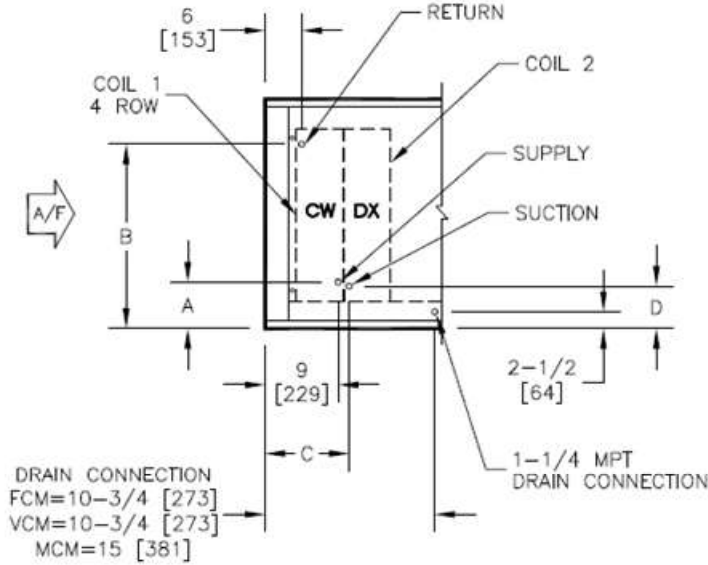

Notes:

1. All Dimensions are inches. All dimensions are +/-1/8" [3mm]. All metric values are rounded to the nearest millimeter.
2. All drawings subject to change without prior notice.
3. Liquid line connection is located inside of cabinet. Field penetration of cabinet is required.
4. See selection program for connection sizes.
5. Direct expansion coils are only available in 3, 4, 6, 8 rows.
6. Chilled water coils are only available in 4, 6, or 8 rows.
7. FCM and VCM can have up to a total of 8 rows of coil.
8. MCM can have up to a total of 10 rows of coil.

Unit Size	3 Row								4 Row								6 Row							
	A		B		C		D		A		B		C		D		A		B		C		D	
	Inches	mm	Inches	mm	Inches	mm	Inches	mm	Inches	mm	Inches	mm	Inches	mm	Inches	mm	Inches	mm	Inches	mm	Inches	mm	Inches	mm
02	6 1/4	159	16 3/4	425	12 1/4	312	4 1/4	108	6 1/4	159	16 3/4	425	12 1/4	312	5	127	6 1/4	159	16 3/4	425	11 3/4	299	5	127
03	6 1/4	159	16 3/4	425	12 1/4	312	4 1/4	108	6 1/4	159	16 3/4	425	12 1/4	312	5	127	6 1/4	159	16 3/4	425	11 3/4	299	5	127
04	6 1/2	165	17	432	12 1/4	312	4 3/4	121	6 1/2	165	17	432	12 1/4	312	5 1/4	134	6 1/2	165	17	432	11 3/4	299	5 1/4	134
06	6 1/2	165	24 1/2	622	12 1/4	312	4 3/4	121	6 1/2	165	24 1/2	622	12 1/4	312	5 1/2	140	6 1/2	165	24 1/2	622	11 3/4	299	6 3/4	172
08	6 3/4	171	29 3/4	756	12 1/4	312	4 3/4	121	6 3/4	171	29 3/4	756	12 1/4	312	5 1/2	140	6 3/4	171	29 3/4	756	11 3/4	299	5 1/2	140
10	6 1/2	165	29 1/2	749	12 1/4	312	4 3/4	121	6 1/2	165	29 1/2	749	12 1/4	312	5 1/2	140	6 1/2	165	29 1/2	749	11 3/4	299	5 1/2	140
12	7 1/4	184	35 1/4	895	12 1/4	312	5 3/4	147	7 1/4	184	35 1/4	895	12 1/4	312	6 1/4	159	7 1/4	184	35 1/4	895	11 3/4	299	6 1/2	166
14	7 1/4	184	37 3/4	959	12 1/4	312	5 3/4	147	7 1/4	184	37 3/4	959	12 1/4	312	6 1/2	166	7 1/4	184	37 3/4	959	11 3/4	299	7 1/2	191
17	7 1/2	191	38	965	12 1/4	312	6	153	7 1/2	191	38	965	12 1/4	312	6 3/4	172	7 1/2	191	38	965	11 3/4	299	8	204

SBM

6 Row Chilled Water w/ Redundant DX Cooling Coil Connection Locations

MCM Segments

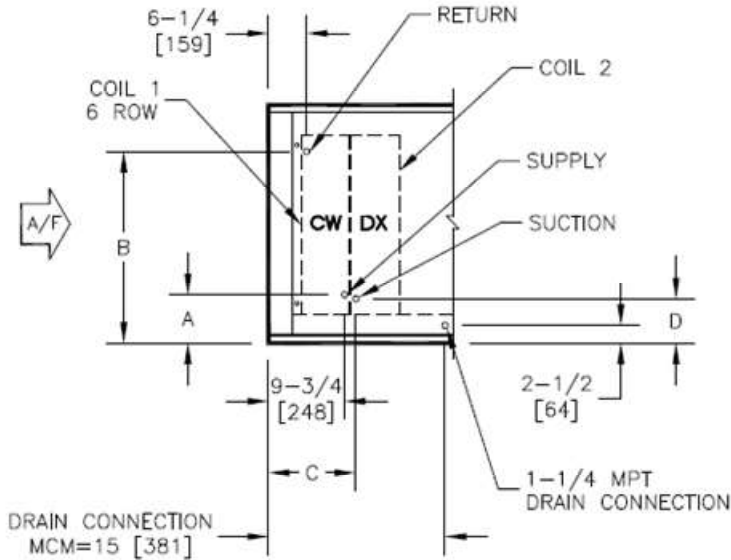

Notes:

1. All Dimensions are inches. All dimensions are +/-1/8" [3mm]. All metric values are rounded to the nearest millimeter.
2. All drawings subject to change without prior notice.
3. Liquid line connection is located inside of cabinet. Field penetration of cabinet is required.
4. See selection program for connection sizes.
5. Direct expansion coils are only available in 3, 4, 6, 8 rows.
6. Chilled water coils are only available in 4, 6, or 8 rows.
7. MCM can have up to a total of 10 rows of coil.

Coil 2																
Unit Size	3 Row								4 Row							
	A		B		C		D		A		B		C		D	
	Inches	mm	Inches	mm	Inches	mm	Inches	mm	Inches	mm	Inches	mm	Inches	mm	Inches	mm
02	6 1/4	159	16 3/4	425	13 1/4	337	4 1/4	108	6 1/4	159	16 3/4	425	13 1/4	337	5	127
03	6 1/4	159	16 3/4	425	13 1/4	337	4 1/4	108	6 1/4	159	16 3/4	425	13 1/4	337	5	127
04	6 1/2	165	17	432	13 1/4	337	4 3/4	121	6 1/2	165	17	432	13 1/4	337	5 1/4	134
06	6 1/2	165	24 1/2	622	13 1/4	337	4 3/4	121	6 1/2	165	24 1/2	622	13 1/4	337	5 1/2	140
08	6 3/4	171	29 3/4	756	13 1/4	337	4 3/4	121	6 3/4	171	29 3/4	756	13 1/4	337	5 1/2	140
10	6 1/2	165	29 1/2	749	13 1/4	337	4 3/4	121	6 1/2	165	29 1/2	749	13 1/4	337	5 1/2	140
12	7 1/4	184	35 1/4	895	13 1/4	337	5 3/4	147	7 1/4	184	35 1/4	895	13 1/4	337	6 1/4	159
14	7 1/4	184	37 3/4	959	13 1/4	337	5 3/4	147	7 1/4	184	37 3/4	959	13 1/4	337	6 1/2	166
17	7 1/2	191	38	965	13 1/4	337	6	153	7 1/2	191	38	965	13 1/4	337	6 3/4	172

SBM

Single Steam Coil Connection Locations

☐ SCM/ MCM/ FCM/ VCM/ STM/ MTM Segments

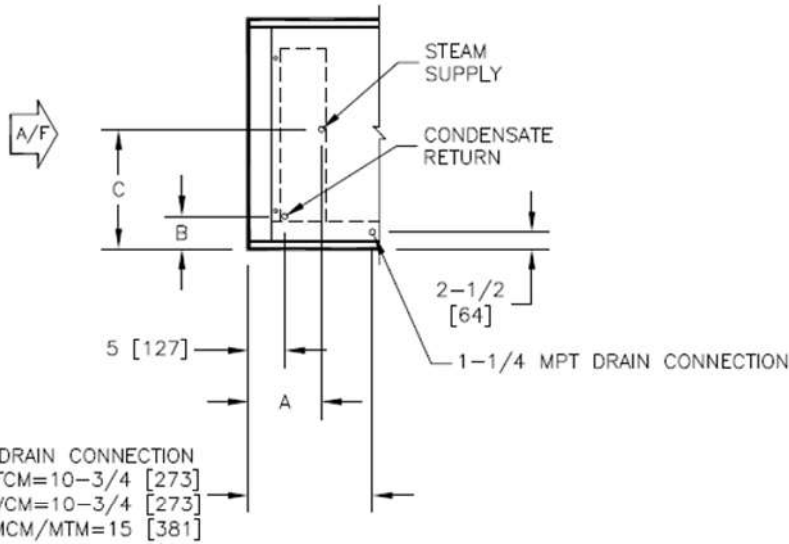

Notes:

1. All Dimensions are inches. All dimensions are +/-1/8" [3mm]. All metric values are rounded to the nearest millimeter.
2. All drawings subject to change without prior notice.
3. See selection program for connection sizes.
4. Steam coils are non-distributing and are only available in 1 & 2 Rows.
5. SCM and STM can have up to 2 rows of a single steam coil and no drain connection.
6. FCM and VCM can have up to a total of 8 rows of coil.
7. MCM and MTM can have up to a total of 10 rows of coil.

Steam Coil

Unit Size	1 Row						2 Row					
	A		B		C		A		B		C	
	Inches	mm	Inches	mm	Inches	mm	Inches	mm	Inches	mm	Inches	mm
02	7 1/4	185	4 3/4	121	11 3/4	298	7	178	5	127	11 3/4	298
03	7 1/4	185	5	127	11 3/4	298	7	178	5	127	11 3/4	298
04	7 1/4	185	5 1/4	133	11 3/4	298	7	178	5 1/4	133	11 3/4	298
06	7 1/4	185	5 1/4	133	15 1/2	394	7	178	5 1/2	140	15 1/2	394
08	7 1/4	185	6 3/4	171	18	457	7	178	5 3/4	146	18	457
10	7 1/4	185	6 1/2	165	18	457	7	178	6 1/2	165	18	457
12	7 1/4	185	7 1/4	184	20 1/2	521	7	178	7 1/4	184	20 1/2	521
14	7 1/4	185	7 1/4	184	21 3/4	552	7	178	7 1/4	184	21 3/4	552
17	7 1/4	185	7 1/2	191	21 3/4	552	7	178	7 1/2	191	21 3/4	552

SBM

1 Row Steam Preheat and Chilled Water Coil Connection Locations

MCM/ FCM/ VCM/ MTM Segments

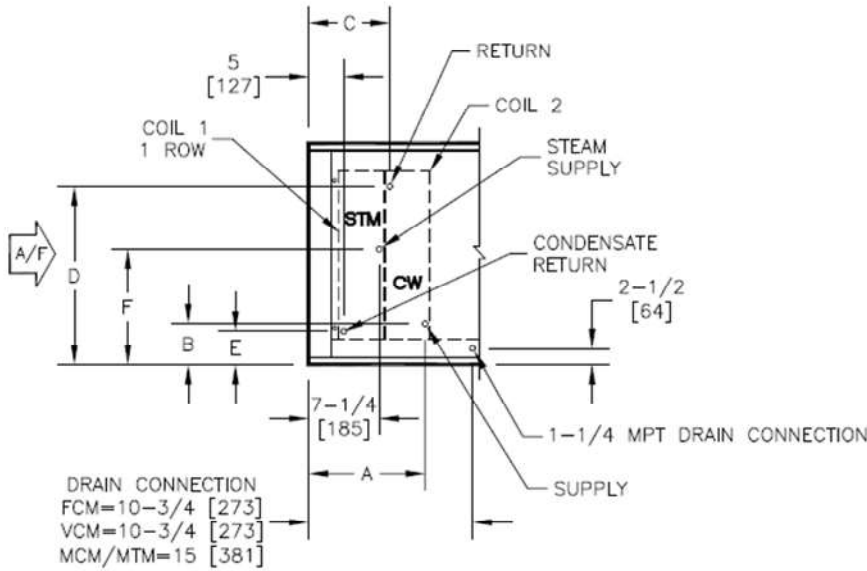

Notes:

1. All Dimensions are inches. All dimensions are +/-1/8" [3mm]. All metric values are rounded to the nearest millimeter.
2. All drawings subject to change without prior notice.
3. See selection program for connection sizes.
4. Chilled water coils are only available in 4, 6, or 8 rows.
5. Steam coils are non-distributing and are only available in 1 & 2 rows.
6. FCM and VCM can have up to a total of 8 rows of coil.
7. MCM and MTM can have up to a total of 10 rows of coil.

Coil 2 Chilled Water																								
Unit Size	4 Row												6 Row											
	A		B		C		D		E		F		A		B		C		D		E		F	
	Inches	mm	Inches	mm	Inches	mm	Inches	mm	Inches	mm	Inches	mm	Inches	mm	Inches	mm	Inches	mm	Inches	mm	Inches	mm	Inches	mm
02	12 1/2	318	6 1/4	159	9 1/2	241	16 3/4	425	4 3/4	121	11 3/4	298	13 1/4	337	6 1/4	159	9 3/4	248	16 3/4	425	4 3/4	121	11 3/4	298
03	12 1/2	318	6 1/4	159	9 1/2	241	16 3/4	425	5	127	11 3/4	298	13 1/4	337	6 1/4	159	9 3/4	248	16 3/4	425	5	127	11 3/4	298
04	12 1/2	318	6 1/2	165	9 1/2	241	17	432	5 1/4	133	11 3/4	298	13 1/4	337	6 1/2	165	9 3/4	248	17	432	5 1/4	133	11 3/4	298
06	12 1/2	318	6 1/2	165	9 1/2	241	24 1/2	622	5 1/4	133	15 1/2	394	13 1/4	337	6 1/2	165	9 3/4	248	24 1/2	622	5 1/4	133	15 1/2	394
08	12 1/2	318	6 3/4	171	9 1/2	241	29 3/4	756	6 3/4	171	18	457	13 1/4	337	6 3/4	171	9 3/4	248	29 3/4	756	6 3/4	171	18	457
10	12 1/2	318	6 1/2	165	9 1/2	241	29 1/2	749	6 1/2	165	18	457	13 1/4	337	6 1/2	165	9 3/4	248	29 1/2	749	6 1/2	165	18	457
12	12 1/2	318	7 1/4	184	9 1/2	241	35 1/4	895	7 1/4	184	20 1/2	521	13 1/4	337	7 1/4	184	9 3/4	248	35 1/4	895	7 1/4	184	20 1/2	521
14	12 1/2	318	7 1/4	184	9 1/2	241	37 3/4	959	7 1/4	184	21 3/4	552	13 1/4	337	7 1/4	184	9 3/4	248	37 3/4	959	7 1/4	184	21 3/4	552
17	12 1/2	318	7 1/2	191	9 1/2	241	38	965	7 1/2	191	21 3/4	552	13 1/4	337	7 1/2	191	9 3/4	248	38	965	7 1/2	191	21 3/4	552

Coil 2 Chilled Water												
Unit Size	8 Row											
	A		B		C		D		E		F	
	Inches	mm	Inches	mm	Inches	mm	Inches	mm	Inches	mm	Inches	mm
02	15 1/4	388	6 1/4	159	9 3/4	127	16 3/4	425	4 3/4	121	11 3/4	298
03	15 1/4	388	6 1/4	159	9 3/4	127	16 3/4	425	5	127	11 3/4	298
04	15 1/4	388	6 1/2	165	9 3/4	127	17	432	5 1/4	133	11 3/4	298
06	15 1/4	388	6 1/2	165	9 3/4	127	24 1/2	622	5 1/4	133	15 1/2	394
08	15 1/4	388	6 3/4	171	9 3/4	127	29 3/4	756	6 3/4	171	18	457
10	15 1/4	388	6 1/2	165	9 3/4	127	29 1/2	749	6 1/2	165	18	457
12	15 1/4	388	7 1/4	184	9 3/4	127	35 1/4	895	7 1/4	184	20 1/2	521
14	15 1/4	388	7 1/4	184	9 3/4	127	37 3/4	959	7 1/4	184	21 3/4	552
17	15 1/4	388	7 1/2	191	9 3/4	127	38	965	7 1/2	191	21 3/4	552

SBM

2 Row Steam Preheat and Chilled Water Coil Connection Locations

☐ MCM/ FCM/ VCM/ MTM Segments

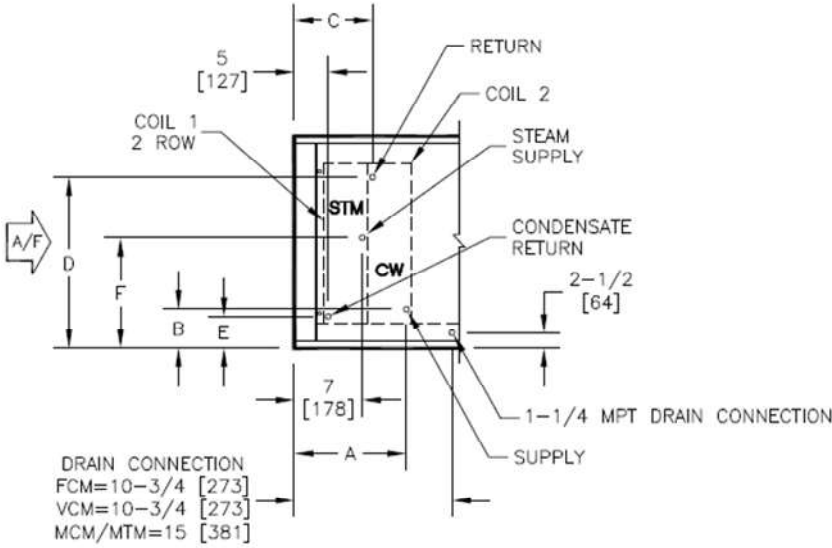

Notes:

1. All Dimensions are inches. All dimensions are +/-1/8" [3mm]. All metric values are rounded to the nearest millimeter.
2. All drawings subject to change without prior notice.
3. See selection program for connection sizes.
4. Chilled water coils are only available in 4, 6, or 8 rows.
5. Steam coils are non-distributing and are only available in 1 & 2 rows.
6. FCM and VCM can have up to a total of 8 rows of coil.
7. MCM and MTM can have up to a total of 10 rows of coil.

Coil 2 Chilled Water																								
Unit Size	4 Row												6 Row											
	A		B		C		D		E		F		A		B		C		D		E		F	
	Inches	mm	Inches	mm	Inches	mm	Inches	mm	Inches	mm	Inches	mm	Inches	mm	Inches	mm	Inches	mm	Inches	mm	Inches	mm		
02	12 1/4	312	6 1/4	159	9 1/4	235	16 3/4	425	5	127	11 3/4	298	13	331	6 1/4	159	9 1/2	241	16 3/4	425	5	127	11 3/4	298
03	12 1/4	312	6 1/4	159	9 1/4	235	16 3/4	425	5	127	11 3/4	298	13	331	6 1/4	159	9 1/2	241	16 3/4	425	5	127	11 3/4	298
04	12 1/4	312	6 1/2	165	9 1/4	235	17	432	5 1/4	133	11 3/4	298	13	331	6 1/2	165	9 1/2	241	17	432	5 1/4	133	11 3/4	298
06	12 1/4	312	6 1/2	165	9 1/4	235	24 1/2	622	5 1/2	140	15 1/2	394	13	331	6 1/2	165	9 1/2	241	24 1/2	622	5 1/2	140	15 1/2	394
08	12 1/4	312	6 3/4	171	9 1/4	235	29 3/4	756	5 3/4	146	18	457	13	331	6 3/4	171	9 1/2	241	29 3/4	756	5 3/4	146	18	457
10	12 1/4	312	6 1/2	165	9 1/4	235	29 1/2	749	6 1/2	165	18	457	13	331	6 1/2	165	9 1/2	241	29 1/2	749	6 1/2	165	18	457
12	12 1/4	312	7 1/4	184	9 1/4	235	35 1/4	895	7 1/4	184	20 1/2	521	13	331	7 1/4	184	9 1/2	241	35 1/4	895	7 1/4	184	20 1/2	521
14	12 1/4	312	7 1/4	184	9 1/4	235	37 3/4	959	7 1/4	184	21 3/4	552	13	331	7 1/4	184	9 1/2	241	37 3/4	959	7 1/4	184	21 3/4	552
17	12 1/4	312	7 1/2	191	9 1/4	235	38	965	7 1/2	191	21 3/4	552	13	331	7 1/2	191	9 1/2	241	38	965	7 1/2	191	21 3/4	552

Coil 2 Chilled Water												
Unit Size	8 Row											
	A		B		C		D		E		F	
	Inches	mm	Inches	mm	Inches	mm	Inches	mm	Inches	mm	Inches	mm
02	15	381	6 1/4	159	9 1/2	241	16 3/4	425	5	127	11 3/4	298
03	15	381	6 1/4	159	9 1/2	241	16 3/4	425	5	127	11 3/4	298
04	15	381	6 1/2	165	9 1/2	241	17	432	5 1/4	133	11 3/4	298
06	15	381	6 1/2	165	9 1/2	241	24 1/2	622	5 1/2	140	15 1/2	394
08	15	381	6 3/4	171	9 1/2	241	29 3/4	756	5 3/4	146	18	457
10	15	381	6 1/2	165	9 1/2	241	29 1/2	749	6 1/2	165	18	457
12	15	381	7 1/4	184	9 1/2	241	35 1/4	895	7 1/4	184	20 1/2	521
14	15	381	7 1/4	184	9 1/2	241	37 3/4	959	7 1/4	184	21 3/4	552
17	15	381	7 1/2	191	9 1/2	241	38	965	7 1/2	191	21 3/4	552

SBM

1 Row Steam Preheat and Direct Expansion Coil Connection Locations

MCM/ FCM/ VCM/ MTM Segments

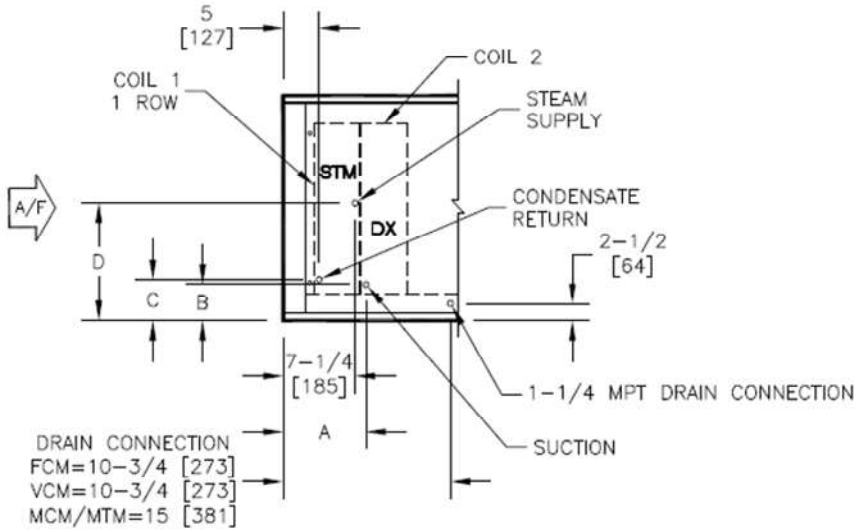

Notes:

1. All Dimensions are inches. All dimensions are +/-1/8" [3mm]. All metric values are rounded to the nearest millimeter.
2. All drawings subject to change without prior notice.
3. Liquid line connection is located inside of cabinet. Field penetration of cabinet is required.
4. See selection program for connection sizes.
5. Direct expansion coils are only available in 3, 4, 6, 8 rows.
6. Steam coils are non-distributing and are only available in 1 & 2 rows.
7. FCM and VCM can have up to a total of 8 rows of coil.
8. MCM and MTM can have up to a total of 10 rows of coil.

Coil 2																
Unit Size	3 Row								4 Row							
	A		B		C		D		A		B		C		D	
	Inches	mm	Inches	mm	Inches	mm	Inches	mm	Inches	mm	Inches	mm	Inches	mm	Inches	mm
02	9 1/2	241	4 1/4	108	4 3/4	121	11 3/4	298	9 1/2	241	5	127	4 3/4	121	11 3/4	298
03	9 1/2	241	4 1/4	108	5	127	11 3/4	298	9 1/2	241	5	127	5	127	11 3/4	298
04	9 1/2	241	4 3/4	121	5 1/4	133	11 3/4	298	9 1/2	241	5 1/4	134	5 1/4	133	11 3/4	298
06	9 1/2	241	4 3/4	121	5 1/4	133	15 1/2	394	9 1/2	241	5 1/2	140	5 1/4	133	15 1/2	394
08	9 1/2	241	4 3/4	121	6 3/4	171	18	457	9 1/2	241	5 1/2	140	6 3/4	171	18	457
10	9 1/2	241	4 3/4	121	6 1/2	165	18	457	9 1/2	241	5 1/2	140	6 1/2	165	18	457
12	9 1/2	241	5 3/4	147	7 1/4	184	20 1/2	521	9 1/2	241	6 1/4	159	7 1/4	184	20 1/2	521
14	9 1/2	241	5 3/4	147	7 1/4	184	21 3/4	552	9 1/2	241	6 1/2	166	7 1/4	184	21 3/4	552
17	9 1/2	241	6	153	7 1/2	191	21 3/4	552	9 1/2	241	6 3/4	172	7 1/2	191	21 3/4	552

Coil 2																
Unit Size	6 Row								8 Row							
	A		B		C		D		A		B		C		D	
	Inches	mm	Inches	mm	Inches	mm	Inches	mm	Inches	mm	Inches	mm	Inches	mm	Inches	mm
02	9	229	5	127	4 3/4	121	11 3/4	298	9	229	5	127	4 3/4	121	11 3/4	298
03	9	229	5	127	5	127	11 3/4	298	9	229	5	127	5	127	11 3/4	298
04	9	229	5 1/4	134	5 1/4	133	11 3/4	298	9	229	5 1/2	140	5 1/4	133	11 3/4	298
06	9	229	6 3/4	172	5 1/4	133	15 1/2	394	9	229	5 1/2	140	5 1/4	133	15 1/2	394
08	9	229	5 1/2	140	6 3/4	171	18	457	9	229	5 1/2	140	6 3/4	171	18	457
10	9	229	5 1/2	140	6 1/2	165	18	457	9	229	5 1/2	140	6 1/2	165	18	457
12	9	229	6 1/2	166	7 1/4	184	20 1/2	521	9	229	6 1/4	159	7 1/4	184	20 1/2	521
14	9	229	7 1/2	191	7 1/4	184	21 3/4	552	9	229	7 3/4	197	7 1/4	184	21 3/4	552
17	9	229	8	204	7 1/2	191	21 3/4	552	9	229	7	178	7 1/2	191	21 3/4	552

SBM

2 Row Steam Preheat and Direct Expansion Coil Connection Locations

MCM/ FCM/ VCM/ MTM Segments

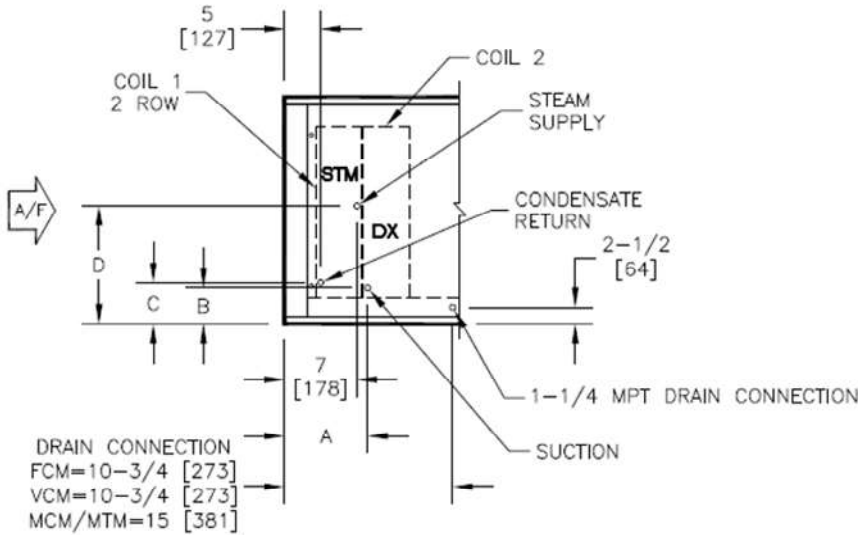

Notes:

1. All Dimensions are inches. All dimensions are +/-1/8" [3mm]. All metric values are rounded to the nearest millimeter.
2. All drawings subject to change without prior notice.
3. Liquid line connection is located inside of cabinet. Field penetration of cabinet is required.
4. See selection program for connection sizes.
5. Direct expansion coils are only available in 3, 4, 6, 8 rows.
6. Steam coils are non-distributing and are only available in 1 & 2 rows.
7. FCM and VCM can have up to a total of 8 rows of coil.
8. MCM and MTM can have up to a total of 10 rows of coil.

Coil 2

Unit Size	3 Row								4 Row							
	A		B		C		D		A		B		C		D	
	Inches	mm	Inches	mm	Inches	mm	Inches	mm	Inches	mm	Inches	mm	Inches	mm	Inches	mm
02	9 1/4	235	4 1/4	108	5	127	11 3/4	298	9 1/4	235	5	127	5	127	11 3/4	298
03	9 1/4	235	4 1/4	108	5	127	11 3/4	298	9 1/4	235	5	127	5	127	11 3/4	298
04	9 1/4	235	4 3/4	121	5 1/4	133	11 3/4	298	9 1/4	235	5 1/4	134	5 1/4	133	11 3/4	298
06	9 1/4	235	4 3/4	121	5 1/2	140	15 1/2	394	9 1/4	235	5 1/2	140	5 1/2	140	15 1/2	394
08	9 1/4	235	4 3/4	121	5 3/4	146	18	457	9 1/4	235	5 1/2	140	5 3/4	146	18	457
10	9 1/4	235	4 3/4	121	6 1/2	165	18	457	9 1/4	235	5 1/2	140	6 1/2	165	18	457
12	9 1/4	235	5 3/4	147	7 1/4	184	20 1/2	521	9 1/4	235	6 1/4	159	7 1/4	184	20 1/2	521
14	9 1/4	235	5 3/4	147	7 1/4	184	21 3/4	552	9 1/4	235	6 1/2	166	7 1/4	184	21 3/4	552
17	9 1/4	235	6	153	7 1/2	191	21 3/4	552	9 1/4	235	6 3/4	172	7 1/2	191	21 3/4	552

Coil 2

Unit Size	6 Row								8 Row							
	A		B		C		D		A		B		C		D	
	Inches	mm	Inches	mm	Inches	mm	Inches	mm	Inches	mm	Inches	mm	Inches	mm	Inches	mm
02	8 3/4	223	5	127	5	127	11 3/4	298	8 3/4	223	5	127	5	127	11 3/4	298
03	8 3/4	223	5	127	5	127	11 3/4	298	8 3/4	223	5	127	5	127	11 3/4	298
04	8 3/4	223	5 1/4	134	5 1/4	133	11 3/4	298	8 3/4	223	5 1/2	140	5 1/4	133	11 3/4	298
06	8 3/4	223	6 3/4	172	5 1/2	140	15 1/2	394	8 3/4	223	5 1/2	140	5 1/2	140	15 1/2	394
08	8 3/4	223	5 1/2	140	5 3/4	146	18	457	8 3/4	223	5 1/2	140	5 3/4	146	18	457
10	8 3/4	223	5 1/2	140	6 1/2	165	18	457	8 3/4	223	5 1/2	140	6 1/2	165	18	457
12	8 3/4	223	6 1/2	166	7 1/4	184	20 1/2	521	8 3/4	223	6 1/4	159	7 1/4	184	20 1/2	521
14	8 3/4	223	7 1/2	191	7 1/4	184	21 3/4	552	8 3/4	223	7 3/4	197	7 1/4	184	21 3/4	552
17	8 3/4	223	8	204	7 1/2	191	21 3/4	552	8 3/4	223	7	178	7 1/2	191	21 3/4	552

SBM

3 Row Direct Expansion and Steam Reheat Coil Connection Locations

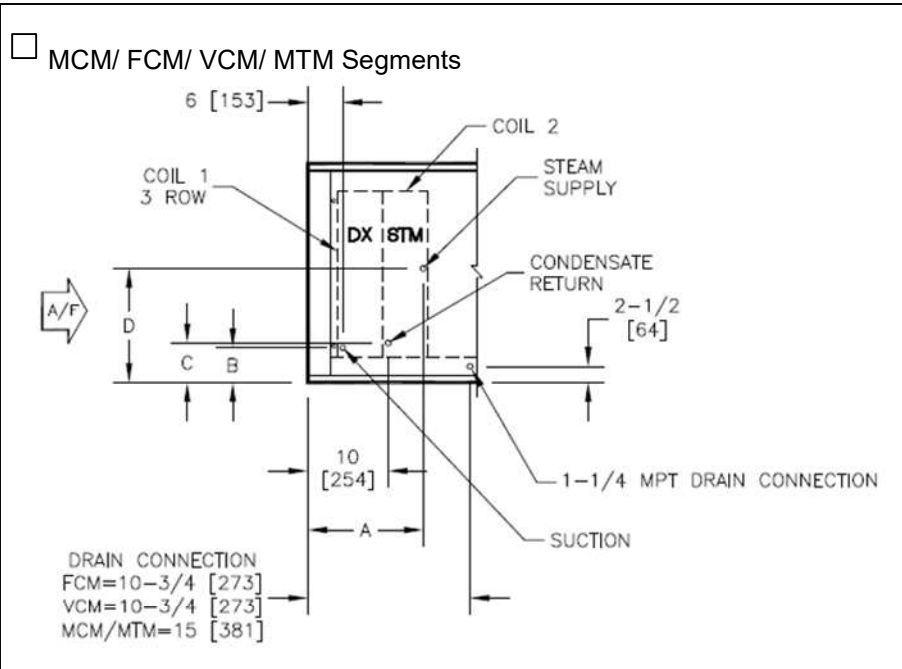

Notes:

1. All Dimensions are inches. All dimensions are +/-1/8" [3mm]. All metric values are rounded to the nearest millimeter.
2. All drawings subject to change without prior notice.
3. Liquid line connection is located inside of cabinet. Field penetration of cabinet is required.
4. See selection program for connection sizes.
5. Direct expansion coils are only available in 3, 4, 6, 8 rows.
6. Steam coils are non-distributing and are only available in 1 & 2 rows.
7. FCM and VCM can have up to a total of 8 rows of coil.
8. MCM and MTM can have up to a total of 10 rows of coil.

Coil 2

Unit Size	1 Row								2 Row							
	A		B		C		D		A		B		C		D	
	Inches	mm	Inches	mm	Inches	mm	Inches	mm	Inches	mm	Inches	mm	Inches	mm	Inches	mm
02	12 1/4	312	4 1/4	108	4 3/4	121	11 3/4	298	12	305	4 1/4	108	5	127	11 3/4	298
03	12 1/4	312	4 1/4	108	5	127	11 3/4	298	12	305	4 1/4	108	5	127	11 3/4	298
04	12 1/4	312	4 3/4	121	5 1/4	133	11 3/4	298	12	305	4 3/4	121	5 1/4	133	11 3/4	298
06	12 1/4	312	4 3/4	121	5 1/4	133	15 1/2	394	12	305	4 3/4	121	5 1/2	140	15 1/2	394
08	12 1/4	312	4 3/4	121	6 3/4	171	18	457	12	305	4 3/4	121	5 3/4	146	18	457
10	12 1/4	312	4 3/4	121	6 1/2	165	18	457	12	305	4 3/4	121	6 1/2	165	18	457
12	12 1/4	312	5 3/4	147	7 1/4	184	20 1/2	521	12	305	5 3/4	147	7 1/4	184	20 1/2	521
14	12 1/4	312	5 3/4	147	7 1/4	184	21 3/4	552	12	305	5 3/4	147	7 1/4	184	21 3/4	552
17	12 1/4	312	6	153	7 1/2	191	21 3/4	552	12	305	6	153	7 1/2	191	21 3/4	552

SBM

4 Row Direct Expansion and Steam Reheat Coil Connection Locations

☐ MCM/ FCM/ VCM/ MTM Segments

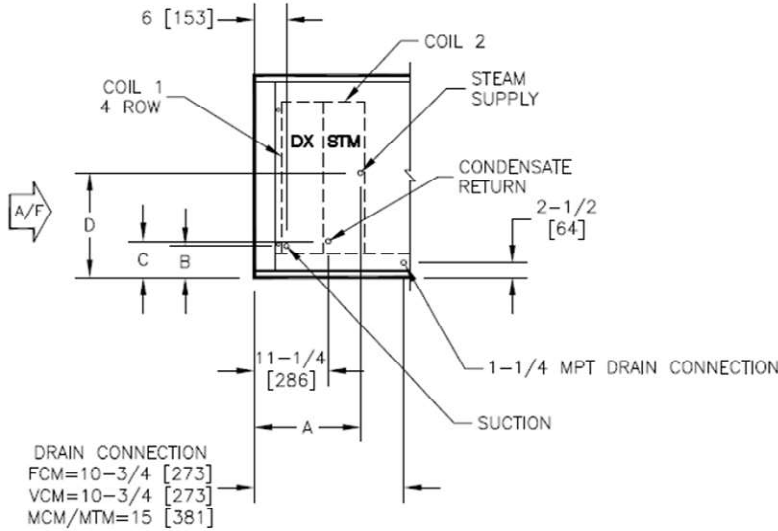

Notes:

1. All Dimensions are inches. All dimensions are +/-1/8" [3mm]. All metric values are rounded to the nearest millimeter.
2. All drawings subject to change without prior notice.
3. Liquid line connection is located inside of cabinet. Field penetration of cabinet is required.
4. See selection program for connection sizes.
5. Direct expansion coils are only available in 3, 4, 6, 8 rows.
6. Steam coils are non-distributing and are only available in 1 & 2 rows.
7. FCM and VCM can have up to a total of 8 rows of coil.
8. MCM and MTM can have up to a total of 10 rows of coil.

Coil 2

Unit Size	1 Row								2 Row							
	A		B		C		D		A		B		C		D	
	Inches	mm	Inches	mm	Inches	mm	Inches	mm	Inches	mm	Inches	mm	Inches	mm	Inches	mm
02	13 1/2	343	4 1/4	108	4 3/4	121	11 3/4	298	13 1/4	337	4 1/4	108	5	127	11 3/4	298
03	13 1/2	343	4 1/4	108	5	127	11 3/4	298	13 1/4	337	4 1/4	108	5	127	11 3/4	298
04	13 1/2	343	4 3/4	121	5 1/4	133	11 3/4	298	13 1/4	337	4 3/4	121	5 1/4	133	11 3/4	298
06	13 1/2	343	4 3/4	121	5 1/4	133	15 1/2	394	13 1/4	337	4 3/4	121	5 1/2	140	15 1/2	394
08	13 1/2	343	4 3/4	121	6 3/4	171	18	457	13 1/4	337	4 3/4	121	5 3/4	146	18	457
10	13 1/2	343	4 3/4	121	6 1/2	165	18	457	13 1/4	337	4 3/4	121	6 1/2	165	18	457
12	13 1/2	343	5 3/4	147	7 1/4	184	20 1/2	521	13 1/4	337	5 3/4	147	7 1/4	184	20 1/2	521
14	13 1/2	343	5 3/4	147	7 1/4	184	21 3/4	552	13 1/4	337	5 3/4	147	7 1/4	184	21 3/4	552
17	13 1/2	343	6	153	7 1/2	191	21 3/4	552	13 1/4	337	6	153	7 1/2	191	21 3/4	552

SBM

6 Row Direct Expansion and Steam Reheat Coil Connection Locations

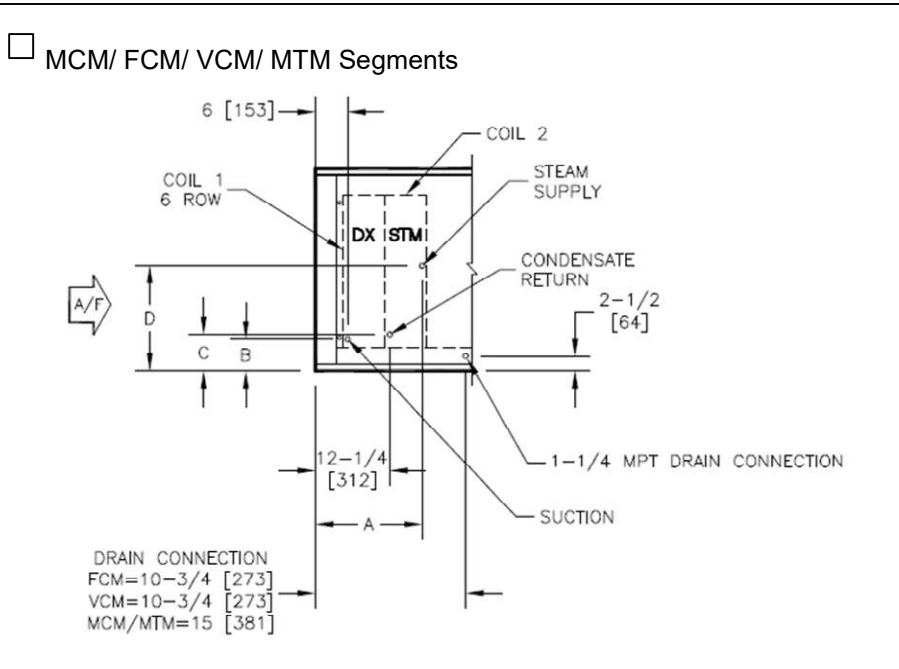

Notes:

1. All Dimensions are inches. All dimensions are +/-1/8" [3mm]. All metric values are rounded to the nearest millimeter.
2. All drawings subject to change without prior notice.
3. Liquid line connection is located inside of cabinet. Field penetration of cabinet is required.
4. See selection program for connection sizes.
5. Direct expansion coils are only available in 3, 4, 6, 8 rows.
6. Steam coils are non-distributing and are only available in 1 & 2 rows.
7. FCM and VCM can have up to a total of 8 rows of coil.
8. MCM and MTM can have up to a total of 10 rows of coil.

Coil 2																
Unit Size	1 Row								2 Row							
	A		B		C		D		A		B		C		D	
	Inches	mm	Inches	mm	Inches	mm	Inches	mm	Inches	mm	Inches	mm	Inches	mm	Inches	mm
02	14 1/2	369	4 1/4	108	4 3/4	121	11 3/4	298	14 1/4	362	4 1/4	108	5	127	11 3/4	298
03	14 1/2	369	4 1/4	108	5	127	11 3/4	298	14 1/4	362	4 1/4	108	5	127	11 3/4	298
04	14 1/2	369	4 3/4	121	5 1/4	133	11 3/4	298	14 1/4	362	4 3/4	121	5 1/4	133	11 3/4	298
06	14 1/2	369	4 3/4	121	5 1/4	133	15 1/2	394	14 1/4	362	4 3/4	121	5 1/2	140	15 1/2	394
08	14 1/2	369	4 3/4	121	6 3/4	171	18	457	14 1/4	362	4 3/4	121	5 3/4	146	18	457
10	14 1/2	369	4 3/4	121	6 1/2	165	18	457	14 1/4	362	4 3/4	121	6 1/2	165	18	457
12	14 1/2	369	5 3/4	147	7 1/4	184	20 1/2	521	14 1/4	362	5 3/4	147	7 1/4	184	20 1/2	521
14	14 1/2	369	5 3/4	147	7 1/4	184	21 3/4	552	14 1/4	362	5 3/4	147	7 1/4	184	21 3/4	552
17	14 1/2	369	6	153	7 1/2	191	21 3/4	552	14 1/4	362	6	153	7 1/2	191	21 3/4	552

SBM

8 Row Direct Expansion and Steam Reheat Coil Connection Locations

MCM/ MTM Segments

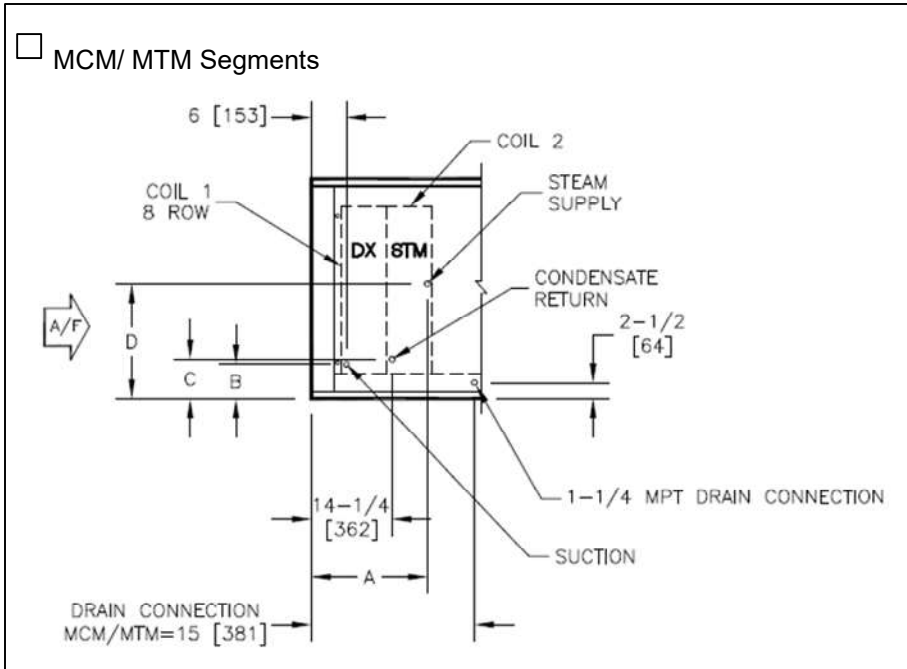

Notes:

1. All Dimensions are inches. All dimensions are +/-1/8" [3mm]. All metric values are rounded to the nearest millimeter.
2. All drawings subject to change without prior notice.
3. Liquid line connection is located inside of cabinet. Field penetration of cabinet is required.
4. See selection program for connection sizes.
5. Direct expansion coils are only available in 3, 4, 6, 8 rows.
6. Steam coils are non-distributing and are only available in 1 & 2 rows.
7. MCM and MTM can have up to a total of 10 rows of coil.

Coil 2																
Unit Size	1 Row								2 Row							
	A		B		C		D		A		B		C		D	
	Inches	mm	Inches	mm	Inches	mm	Inches	mm	Inches	mm	Inches	mm	Inches	mm	Inches	mm
02	16 1/2	420	4 1/4	108	4 3/4	121	11 3/4	298	16 1/4	413	4 1/4	108	5	127	11 3/4	298
03	16 1/2	420	4 1/4	108	5	127	11 3/4	298	16 1/4	413	4 1/4	108	5	127	11 3/4	298
04	16 1/2	420	4 3/4	121	5 1/4	133	11 3/4	298	16 1/4	413	4 3/4	121	5 1/4	133	11 3/4	298
06	16 1/2	420	4 3/4	121	5 1/4	133	15 1/2	394	16 1/4	413	4 3/4	121	5 1/2	140	15 1/2	394
08	16 1/2	420	4 3/4	121	6 3/4	171	18	457	16 1/4	413	4 3/4	121	5 3/4	146	18	457
10	16 1/2	420	4 3/4	121	6 1/2	165	18	457	16 1/4	413	4 3/4	121	6 1/2	165	18	457
12	16 1/2	420	5 3/4	147	7 1/4	184	20 1/2	521	16 1/4	413	5 3/4	147	7 1/4	184	20 1/2	521
14	16 1/2	420	5 3/4	147	7 1/4	184	21 3/4	552	16 1/4	413	5 3/4	147	7 1/4	184	21 3/4	552
17	16 1/2	420	6	153	7 1/2	191	21 3/4	552	16 1/4	413	6	153	7 1/2	191	21 3/4	552

SBM

4 Row Chilled Water and Steam Reheat Coil Connection Locations

MCM/ FCM/ VCM/ MTM Segments

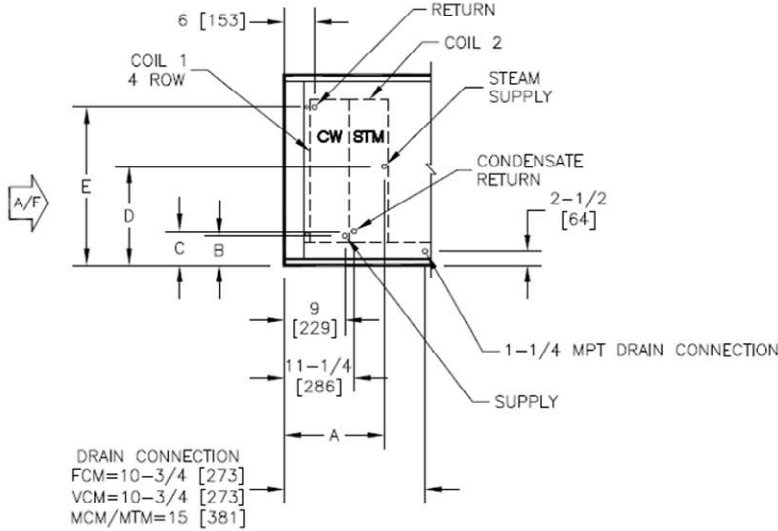

Notes:

1. All Dimensions are inches. All dimensions are +/-1/8" [3mm]. All metric values are rounded to the nearest millimeter.
2. All drawings subject to change without prior notice.
3. See selection program for connection sizes.
4. Chilled water coils are only available in 4, 6, or 8 rows.
5. Steam coils are non-distributing and are only available in 1 & 2 rows.
6. FCM and VCM can have up to a total of 8 rows of coil.
7. MCM and MTM can have up to a total of 10 rows of coil.

Unit Size		Coil 2																		
		1 Row									2 Row									
		A		B		C		D		E		A		B		C		D		E
Inches	mm	Inches	mm	Inches	mm	Inches	mm	Inches	mm	Inches	mm	Inches	mm	Inches	mm	Inches	mm	Inches	mm	
02	13 1/2	343	4 1/4	108	4 3/4	121	11 3/4	298	16 3/4	425	13 1/4	337	4 1/4	108	5	127	11 3/4	298	16 3/4	425
03	13 1/2	343	4 1/4	108	5	127	11 3/4	298	16 3/4	425	13 1/4	337	4 1/4	108	5	127	11 3/4	298	16 3/4	425
04	13 1/2	343	4 3/4	121	5 1/4	133	11 3/4	298	17	432	13 1/4	337	4 3/4	121	5 1/4	133	11 3/4	298	17	432
06	13 1/2	343	4 3/4	121	5 1/4	133	15 1/2	394	24 1/2	622	13 1/4	337	4 3/4	121	5 1/2	140	15 1/2	394	24 1/2	622
08	13 1/2	343	4 3/4	121	6 3/4	171	18	457	29 3/4	756	13 1/4	337	4 3/4	121	5 3/4	146	18	457	29 3/4	756
10	13 1/2	343	4 3/4	121	6 1/2	165	18	457	29 1/2	749	13 1/4	337	4 3/4	121	6 1/2	165	18	457	29 1/2	749
12	13 1/2	343	5 3/4	147	7 1/4	184	20 1/2	521	35 1/4	985	13 1/4	337	5 3/4	147	7 1/4	184	20 1/2	521	35 1/4	985
14	13 1/2	343	5 3/4	147	7 1/4	184	21 3/4	552	37 3/4	959	13 1/4	337	5 3/4	147	7 1/4	184	21 3/4	552	37 3/4	959
17	13 1/2	343	6	153	7 1/2	191	21 3/4	552	38	965	13 1/4	337	6	153	7 1/2	191	21 3/4	552	38	965

SBM

6 Row Chilled Water and Steam Reheat Coil Connection Locations

☐ MCM/ FCM/ VCM/ MTM Segments

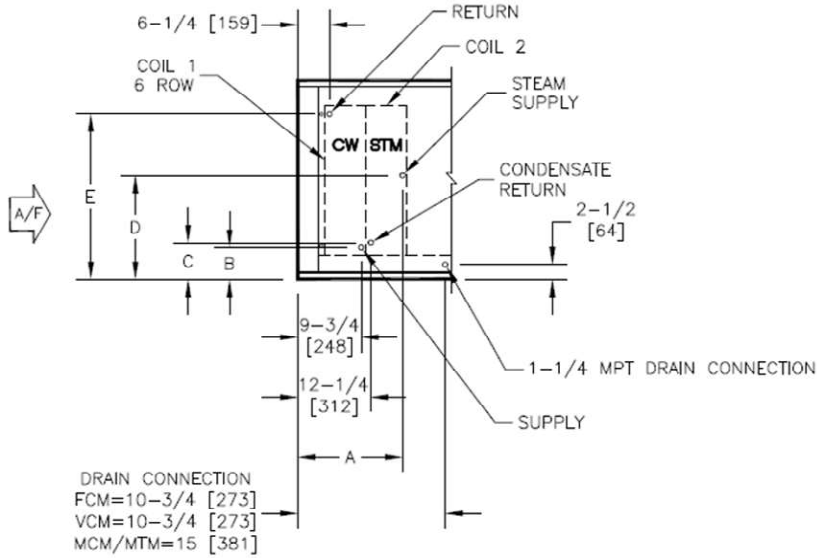

Notes:

1. All Dimensions are inches. All dimensions are +/-1/8" [3mm]. All metric values are rounded to the nearest millimeter.
2. All drawings subject to change without prior notice.
3. See selection program for connection sizes.
4. Chilled water coils are only available in 4, 6, or 8 rows.
5. Steam coils are non-distributing and are only available in 1 & 2 rows.
6. FCM and VCM can have up to a total of 8 rows of coil.
7. MCM and MTM can have up to a total of 10 rows of coil.

Coil 2

Unit Size	1 Row										2 Row									
	A		B		C		D		E		A		B		C		D		E	
	Inches	mm	Inches	mm	Inches	mm	Inches	mm	Inches	mm	Inches	mm	Inches	mm	Inches	mm	Inches	mm	Inches	mm
02	14 1/2	369	4 1/4	108	4 3/4	121	11 3/4	298	16 3/4	425	14 1/4	362	4 1/4	108	5	127	11 3/4	298	16 3/4	425
03	14 1/2	369	4 1/4	108	5	127	11 3/4	298	16 3/4	425	14 1/4	362	4 1/4	108	5	127	11 3/4	298	16 3/4	425
04	14 1/2	369	4 3/4	121	5 1/4	133	11 3/4	298	17	432	14 1/4	362	4 3/4	121	5 1/4	133	11 3/4	298	17	432
06	14 1/2	369	4 3/4	121	5 1/4	133	15 1/2	394	24 1/2	622	14 1/4	362	4 3/4	121	5 1/2	140	15 1/2	394	24 1/2	622
08	14 1/2	369	4 3/4	121	6 3/4	171	18	457	29 3/4	756	14 1/4	362	4 3/4	121	5 3/4	146	18	457	29 3/4	756
10	14 1/2	369	4 3/4	121	6 1/2	165	18	457	29 1/2	749	14 1/4	362	4 3/4	121	6 1/2	165	18	457	29 1/2	749
12	14 1/2	369	5 3/4	147	7 1/4	184	20 1/2	521	35 1/4	985	14 1/4	362	5 3/4	147	7 1/4	184	20 1/2	521	35 1/4	985
14	14 1/2	369	5 3/4	147	7 1/4	184	21 3/4	552	37 3/4	959	14 1/4	362	5 3/4	147	7 1/4	184	21 3/4	552	37 3/4	959
17	14 1/2	369	6	153	7 1/2	191	21 3/4	552	38	965	14 1/4	362	6	153	7 1/2	191	21 3/4	552	38	965

SBM

8 Row Chilled Water and Steam Reheat Coil Connection Locations

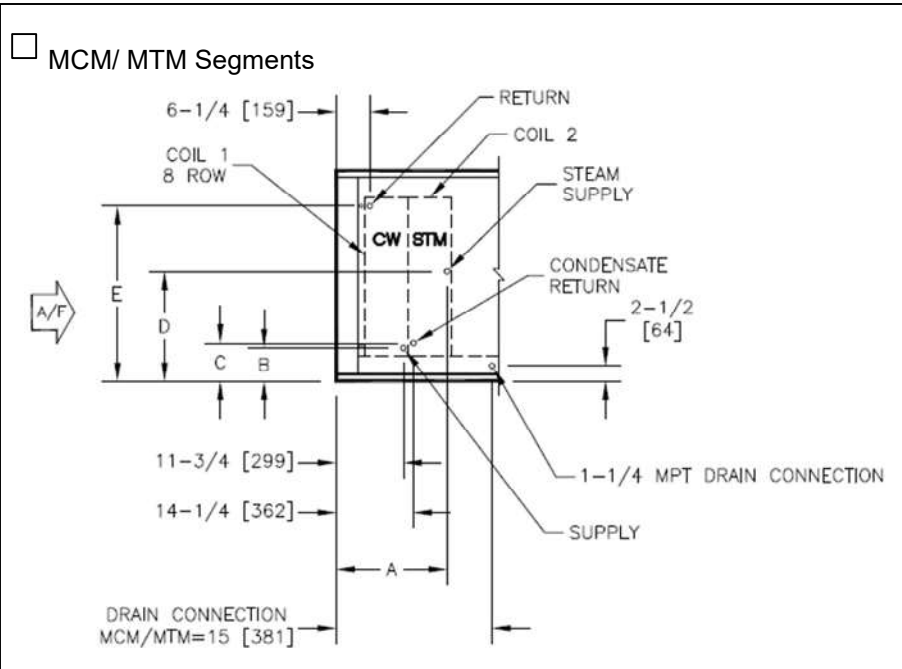

Notes:

1. All Dimensions are inches. All dimensions are +/-1/8" [3mm]. All metric values are rounded to the nearest millimeter.
2. All drawings subject to change without prior notice.
3. See selection program for connection sizes.
4. Chilled water coils are only available in 4, 6, or 8 rows.
5. Steam coils are non-distributing and are only available in 1 & 2 rows.
6. MCM and MTM can have up to a total of 10 rows of coil.

Coil 2																				
Unit Size	1 Row										2 Row									
	A		B		C		D		E		A		B		C		D		E	
	Inches	mm	Inches	mm	Inches	mm	Inches	mm	Inches	mm	Inches	mm	Inches	mm	Inches	mm	Inches	mm	Inches	mm
02	16 1/2	420	4 1/4	108	4 3/4	121	11 3/4	298	16 3/4	425	16 1/4	413	4 1/4	108	5	127	11 3/4	298	16 3/4	425
03	16 1/2	420	4 1/4	108	5	127	11 3/4	298	16 3/4	425	16 1/4	413	4 1/4	108	5	127	11 3/4	298	16 3/4	425
04	16 1/2	420	4 3/4	121	5 1/4	133	11 3/4	298	17	432	16 1/4	413	4 3/4	121	5 1/4	133	11 3/4	298	17	432
06	16 1/2	420	4 3/4	121	5 1/4	133	15 1/2	394	24 1/2	622	16 1/4	413	4 3/4	121	5 1/2	140	15 1/2	394	24 1/2	622
08	16 1/2	420	4 3/4	121	6 3/4	171	18	457	29 3/4	756	16 1/4	413	4 3/4	121	5 3/4	146	18	457	29 3/4	756
10	16 1/2	420	4 3/4	121	6 1/2	165	18	457	29 1/2	749	16 1/4	413	4 3/4	121	6 1/2	165	18	457	29 1/2	749
12	16 1/2	420	5 3/4	147	7 1/4	184	20 1/2	521	35 1/4	985	16 1/4	413	5 3/4	147	7 1/4	184	20 1/2	521	35 1/4	985
14	16 1/2	420	5 3/4	147	7 1/4	184	21 3/4	552	37 3/4	959	16 1/4	413	5 3/4	147	7 1/4	184	21 3/4	552	37 3/4	959
17	16 1/2	420	6	153	7 1/2	191	21 3/4	552	38	965	16 1/4	413	6	153	7 1/2	191	21 3/4	552	38	965